

U.S. DEPARTMENT OF ENERGY – BONNEVILLE POWER ADMINISTRATION (BPA)
APPLICATION FOR PROPOSED USE OF BPA RIGHT-OF-WAY

Privacy Act Statement:

Authority: 42 USC § 7101 and 50 USC § 2401

Purpose: BPA will use this information to assess whether your proposed use of our right-of-way will interfere with BPA's land rights.

Routine Uses: This information is authorized to be maintained in Privacy Act system of records DOE-24, "Land Records System." Other routine uses for which this information may be disclosed are listed in the Privacy Act system of records notice for DOE-24, which is published in the Federal Register.

Disclosure: Voluntary; however, failure to provide complete information may result in a delay or denial of your application.

INSTRUCTIONS: Applicant is required to complete all of page 1 and 2. If not submitting an attached map, plan or sketch, page 3 is required.

Payment must be made electronically. To make a payment go to: <https://www.bpa.gov/goto/HowtoPay>: Select "BPA online payments" hyperlink. In the form please fill in all the required fields. Under Purpose of Payment select REALTY APPLICATION FEE. Please make sure to select the appropriate box below before making your payment. You should receive a confirmation when finished.

No Application Fee: For individual landowners requesting personal use of BPA Right-of-Way.

\$250 Application Fee: For developments or subdivisions. Application fee is non-refundable.

\$2500 Application Fee: For longitudinal occupancies that require multiple miles of BPA Right-of-Way. Application fee is non-refundable.

Ask for Real Property Services at : 1-800-282-3713/www.bpa.gov/goto/LandsCommunity

1. Date _____

2. Applicant Information:

Applicant Name _____ Phone Number _____ Fax Number _____

Address: Street _____ City _____ State _____

ZIP Code _____ Email Address _____

3. Owner Information (Complete only if the applicant is not the owner):

Owner Name _____ Phone Number _____ Fax Number _____

Address: Street _____ City _____ State _____

ZIP Code _____ Email Address _____

4. Legal description of the property (This information is on your title, insurance policy, courthouse deed, or your tax statement.)

Note: Applicant must provide a county assessor's map showing the owner's boundary lines and the location of use.

Location Of Property:

Quarter Section(s) Section(s) Township Range County State

APPLICATION FOR PROPOSED USE OF BPA RIGHT-OF-WAY

5. Purpose For Which BPA Right-Of-Way/Property Is To Be Used. Check all boxes that apply and complete the information on the following page. (Include a map, plan or sketch if appropriate.)

NOTE: For submission of digital plans please provide a PDF version. BPA will request larger plans, if needed.

Driveway/Roadway Width (**Note:** Please attach existing and proposed grading plans)

Width _____ Material _____

Electric Service Line

Voltage _____ Underground _____ Overhead _____

Pipelines	Type:	Gas	Sewer	Water
	Diameter	_____	_____	_____
	Material	_____	_____	_____
	Buried Depth	_____	_____	_____

Customer Interconnection Request Number (*for interconnection requests only*) _____

Other Uses: Please describe your intended use in detail. In order to assure safe clearance, please describe any equipment that will be used for applied use (*including equipment intended to construct and maintain the use*). Space is provided on page 3 for a drawing. If grading, please attach existing and proposed grading plans.

6. Applicant Name _____ 7. Applicant Title _____

8. Applicant Signature _____

APPLICATION FOR PROPOSED USE OF BPA RIGHT-OF-WAY

Applicant Name _____

Complete **ONLY** if overhead or underground foreign line crosses an overhead BPA line. If the foreign line crosses more than one BPA line use additional sheets.

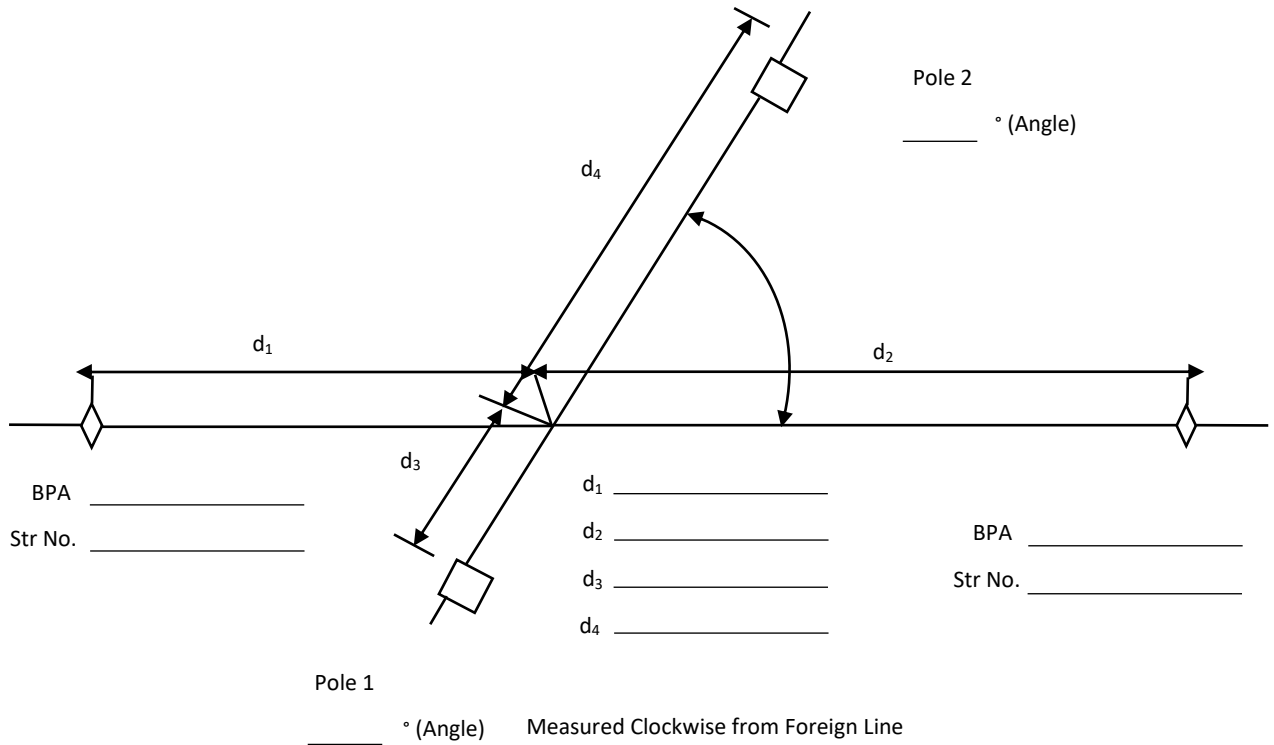

PLAN

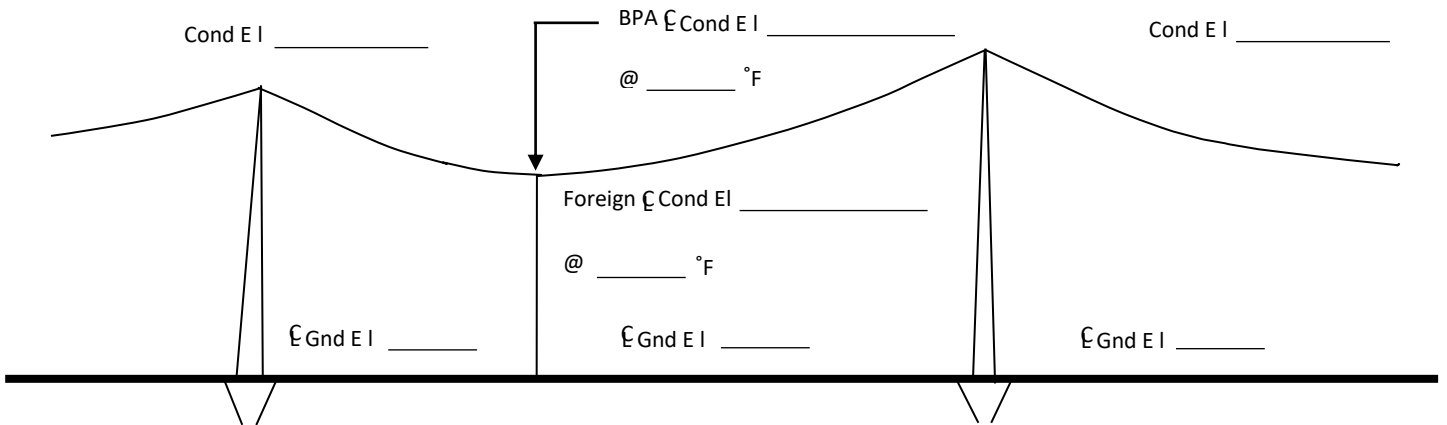

APPLICATION FOR PROPOSED USE OF BPA RIGHT-OF-WAY

Applicant Name _____

Elevation BPA line

Poles	Length	Depth Set	Class Pole
Pole 1			
Pole 2			

Fixtures

Size of Crossarms _____

Make & Catalog Number Of Insulators:

Conductors

Number _____ Size _____

Kind _____ Voltage _____

MWT _____ Loading _____

Comments:

Pole 1 Configurations _____

Pole 2 Configurations _____

To submit digitally contact the District Office nearest to your project and the Realty Specialist will provide you with an email address.
If mailing, send your application to the location nearest to your project:

WESTERN WASHINGTON

Location and Address	Phone Number
Snohomish District Office, 914 Ave D, Snohomish, WA 98290	360-563-3640
Covington District Office, PO Box 3621, Portland, OR 97208-3621	253-638-3741
Olympia District Office, 5240 Trosper St SW, Olympia, WA 98512	360-570-4352, 360-570-4333 OR 360-570-4332
Ross Maint. Hdqt. Office, PO Box 3621, Portland, OR 97208-3621	800-836-6691

OREGON

Location and Address	Phone Number
Redmond District Office, 3655 SW Highland Ave., Redmond, OR 97756	541-516-3200
Eugene District Office, 86000 Hwy 99S, Eugene, OR 97405	541-988-7432
Salem District Office, 2715 Tepper Lane, Keizer, OR 97303	503-304-5900
Portland Office, PO Box 3621, Portland, OR 97208-3621	800-836-6619
Hood River, <i>(see Portland for mailing address)</i>	
North Bend Area, <i>(see Portland for mailing address)</i>	

EASTERN WASHINGTON, IDAHO AND MONTANA

Location and Address	Phone Number
Idaho Falls District Office, <i>(see Tri-Cities Pasco, WA mailing address)</i>	509-544-4747
Tri-Cities District Office, <i>(OR Side)</i> , 2211 North Commercial Avenue, Pasco, WA 99301	509-544-4747
Tri-Cities <i>(WA side)</i> , 2211 North Commercial Avenue, Pasco, WA 99301	503-230-5510
Spokane District Office, 2410 E. Hawthorne Rd., Mead, WA 99021-9594	509-468-3081
Grand Coulee Area, PO Box 24, Grand Coulee, WA 99133	509-378-7447
Ellensburg Area, PO Box 3621, Portland, OR 97208-3621	503-230-5611
Kalispell Maintenance District Office, 2520 US Hwy 2 East, Kalispell, MT 59901	406-751-7824

Paperwork Reduction Act Burden Disclosure Statement

This data is being collected to complete an application for proposed use of BPA right-of-way to assess whether it will interfere with BPA's land rights. The information you provide will be used by realty and finance personnel to make a determination regarding the use BPA's right-of-way as per your request. Public reporting burden for this collection of information is estimated to average 1 hour per response, including the time for reviewing instructions, searching existing data sources, gathering and maintaining that data needed, and completing and reviewing the collection of information. Send comments regarding this burden estimate or any other aspect of this collection of information, including suggestions for reducing this burden, to Office of the Chief Information Officer, Enterprise Policy Development & Implementation Office, IM-22, Paperwork Reduction Project OMB control number 1910-5205. U.S. Department of Energy, 1000 Independence Ave SW, Washington, DC, 20585-1290; and to the Office of Management and Budget (OMB), OIRA, Paperwork Reduction Project (OMB control number: 1910-5205), Washington, DC 20503.

Notwithstanding any other provision of the law, no person is required to respond to, nor shall any person be subject to a penalty for failure to comply with a collection of information subject to the requirements of the Paperwork Reduction Act unless that collection of information displays a currently valid OMB control number.

The Paperwork Reduction Act (PRA) of 1995 requires each Federal agency to seek and obtain approval from the Office of Management and Budget (OMB) before undertaking a collection of information directed to 10 or more persons of the general public, including persons involved in or supporting the operations of Government-owned, contractor-operated facilities.

Submission of this information is voluntary.