

## System 013 - Site 501439, Vancouver, WA

Site 501439 is a grocery store located in Vancouver WA. There are two refrigeration circuits--a low temperature Rack A on Circuit 13 and a medium temperature Rack B on Circuit 12 – installed in approximately 2005.

### Circuit 12, Medium Temperature and Circuit 13, Low Temperature

Circuit 12 (Rack B) is a medium temperature multiplex system Circuit 13 (Rack A) is a low temperature multiplex system, both with R404a refrigerant located in Vancouver, WA. Each rack has with 3 compressors. This system is unusual in that the two racks share a single condenser unit. The compressors all discharge into a single manifold, but the low and medium temperature racks each have a separate suction manifold. The discharge line has a desuperheater that allows heat recovery from hot discharge gas to heat hot water and decrease the gas temperature before entering the condenser. Compressors have head fans, which reduces the gas temperature at the compressor discharge to prevent compressor overheating. The system has sixteen evaporator circuits, nine on the low temperature side and seven on the medium temperature side. Both racks share a single Emerson E2 refrigeration system controller.

**Table 1. Measured data on Circuit 13**

Measured Data	Variable Name(s)	Point Number
Outdoor Temperature	TT_OUTDOOR	--
Discharge Temperatures after each Compressor	MISC1 to MISC3	2
Common Discharge Temperature	TT_RCOMP_OUT	2
Common Discharge Temperature Before Desuperheater	TT_X8	
Low Temperature Common Suction Temperature	TT_RCOMP_IN	1
Compressor Power	EP_COMP	--
Low Pressure, Suction Manifold	PT_RLP	1
High Pressure, Discharge Manifold	PT_RHP	2
Condenser Entering Temperature	TT_RCOND_IN	3
Condenser Fan Power	MISC10	--
Condenser Discharge Temperature	TT_RCOND_OUT	6
Liquid Line Temperature entering expansion device	TT_REXP_IN	7

**Figure 1. Pressure-enthalpy diagram for basic refrigeration cycle, neglecting pressure losses.**

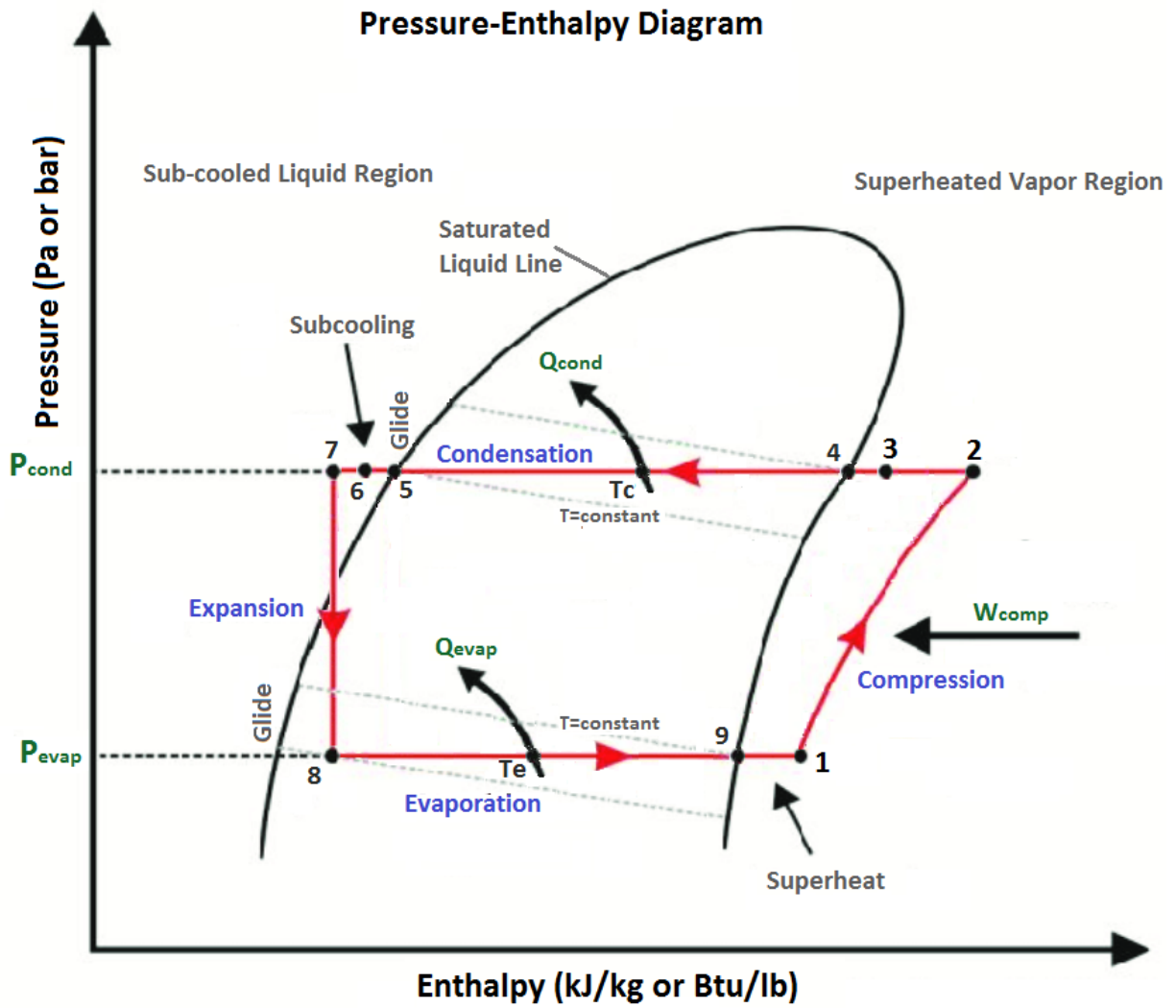

Figure 2. Circuits 12 and 13 ClimaCheck system diagram

CIRCUIT 12, MEDIUM TEMPERATURE RACK  
 CIRCUIT 13, LOW TEMPERATURE RACK

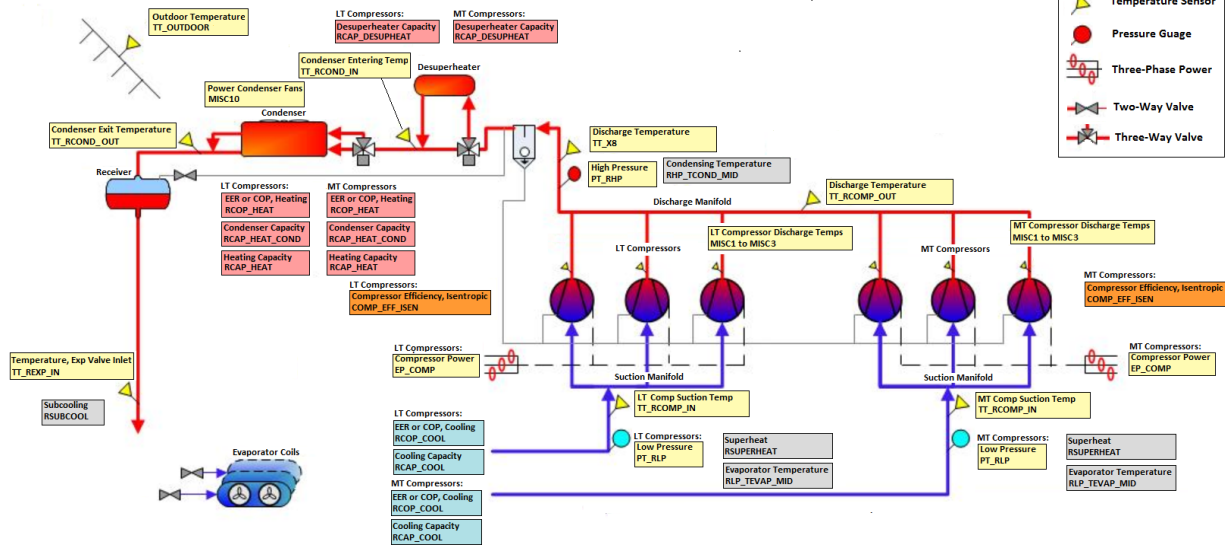

Table 2. Calculated values on Circuit 13

Calculated/Derived Values	Variable Name	Measured Temperatures Used in Calculations	Point Number/Process
Isentropic Compressor Efficiency	COMP_EFF_ISEN	Discharge and suction manifold conditions	1 to 2
Condensing Temperature	RHP_TCOND_MID	Dew point and bubble point temperatures at PT_RHP	c
Evaporator Temperature	RLP_TEVAP_MID	Dew point and bubble point temperatures temperature at PT_RLP	e
Heating COP	RCOP_HEAT	TT_REXP_IN, Discharge and suction manifold temperatures	3 to 6
Condenser Capacity	RCAP_HEAT_COND	TT_RCOND_IN, TT_REXP_IN	
Heating Capacity	RCAP_HEAT	TT_RCOND_IN, TT_REXP_IN	
Cooling COP	RCOP_COOL	TT_RCOND_IN, TT_REXP_IN, Discharge and Suction Temperatures	8 to 1
Cooling Capacity	RCAP_COOL	TT_REXP_IN, Suction Temperatures	
Subcooling	RSUBCOOL	TT_REXP_IN, Bubble point temperature at PT_RHP	5 to 7
Superheat	RSUPERHEAT	Suction temperatures, Dew point temperature at PT_RLP	9 to 1