



**US Army Corps  
of Engineers®**  
Portland District



---

# **WILLAMETTE VALLEY SYSTEM OPERATIONS AND MAINTENANCE**

## **APPENDIX F2: SUPPLEMENTAL CLIMATE CHANGE INFORMATION**

**TABLE OF CONTENTS**

**1. Introduction ..... 1**

**2. Relevant climate change factors..... 2**

**3. Supplemental data Sources..... 4**

    3.1 Overview of RMJOC-II Climate Change Projections..... 5

        3.1.1 Temperature ..... 6

        3.1.2 Precipitation..... 8

        3.1.3 Snow Water Equivalent (SWE)..... 10

        3.1.4 Naturalized Streamflow ..... 10

        3.1.5 Wildfire ..... 11

        3.1.6 Invasive Species ..... 14

    3.2 Climate Change in the Willamette River Subbasins..... 14

        3.2.1 Current Regulations ..... 16

        3.2.2 Climate Change Projections ..... 18

        3.2.3 Key to Summary Hydrograph Figures ..... 18

        3.2.4 Middle Willamette River ..... 19

        3.2.5 Upper Willamette River Subbasin..... 27

        3.2.6 North Santiam River Subbasin ..... 33

        3.2.7 South Santiam River Subbasin ..... 40

        3.2.8 McKenzie River Subbasin ..... 47

        3.2.9 Middle Fork Willamette River Subbasin ..... 54

        3.2.10 Coast Fork Willamette River Subbasin..... 64

        3.2.11 Long Tom River Subbasin ..... 72

**4. References..... 79**

**LIST OF FIGURES**

Figure 3-1. Projected Willamette River Basin Average Temperature Change (RMJOC 2018). .....	7
Figure 3-2. NOAA Annual Observed Temperatures.....	8
Figure 3-3. Projected Willamette River Basin Average Precipitation Change (RMJOC 2018). .....	9
Figure 3-4. Projected Willamette River Basin Average Snow Water Equivalent (RMJOC 2018). .....	10
Figure 3-5. Projected Willamette River Basin Average Naturalized Streamflows (RMJOC 2018). .....	11
Figure 3-6. Salem, Oregon Annual Very High Fire Danger Days. ....	13
Figure 3-7. Willamette River Basin Subbasins. ....	15
Figure 3-8. WVS Regulation Schematic.....	17
Figure 3-9. IPCC Representative Concentration Pathways (RCPs).....	18
Figure 3-10. Example Historical and Future Predictions Graph.....	19
Figure 3-11. Middle Willamette River Subbasin. ....	20
Figure 3-12. Average Annual Temperature Trends at Salem, Oregon, 1950–2100. ....	22
Figure 3-13. Average Annual Summer Temperature Trends at Salem, Oregon, 1950–2100.....	22
Figure 3-14. Median Winter Precipitation Trends at Salem, Oregon, 1950–2100.....	23
Figure 3-15. Median Summer Precipitation Trends at Salem, Oregon, 1950–2100. ....	23
Figure 3-16. Willamette River at Salem, Oregon Summary Hydrographs.....	25
Figure 3-17. Salem, Oregon Annual Very High Fire Danger Days. ....	27
Figure 3-18. Upper Willamette River Subbasin. ....	28
Figure 3-19. Average Annual Temperature Trends at Eugene, Oregon, 1950–2100. ....	29
Figure 3-20. Average Annual Summer Temperature Trends at Eugene, Oregon, 1950–2100.....	29
Figure 3-21. Median Winter Precipitation Trends at Eugene, Oregon, 1950–2100.....	30
Figure 3-22. Median Summer Precipitation Trends at Eugene, Oregon, 1950–2100. ....	30
Figure 3-23. Willamette River at Albany, Oregon Summary Hydrographs.....	31
Figure 3-24. Albany, Oregon Annual Very High Fire Danger Days.....	33
Figure 3-25. North Santiam River Subbasin.....	34
Figure 3-26. Average Annual Temperature Trends at Detroit, Oregon, 1950–2100.....	35
Figure 3-27. Average Annual Summer Temperature Trends at Detroit, Oregon, 1950–2100.....	35
Figure 3-28. Median Winter Precipitation Trends at Detroit, Oregon, 1950–2100. ....	36
Figure 3-29. Median Summer Precipitation Trends at Detroit, Oregon, 1950–2100.....	36
Figure 3-30. North Santiam River at Detroit Dam, Oregon Summary Hydrographs. ....	38

*Willamette Valley System Operations and Maintenance  
Environmental Impact Statement*

Figure 3-31. Detroit, Oregon Annual Very High Fire Danger Days. ....	40
Figure 3-32. South Santiam River Subbasin.....	41
Figure 3-33. Average Annual Temperature Trends at Green Peter Dam, Oregon, 1950– 2100.....	42
Figure 3-34. Average Annual Summer Temperature Trends at Green Peter Dam, Oregon, 1950–2100. ....	42
Figure 3-35. Median Winter Precipitation Trends at Green Peter Dam, Oregon, 1950– 2100.....	43
Figure 3-36. Median Summer Precipitation Trends at Green Peter Dam, Oregon, 1950– 2100.....	43
Figure 3-37. South Santiam River at Green Peter Dam, Oregon Summary Hydrographs.....	45
Figure 3-38. Green Peter Dam, Oregon Annual Very High Fire Danger Days.....	46
Figure 3-39. McKenzie River Subbasin.....	47
Figure 3-40. Average Annual Temperature Trends at Cougar Dam, Oregon, 1950–2100. ....	48
Figure 3-41. Average Annual Summer Temperature Trends at Cougar Dam, Oregon, 1950–2100. ....	49
Figure 3-42. Median Winter Precipitation Trends at Cougar Dam, Oregon, 1950–2100.....	49
Figure 3-43. Median Summer Precipitation Trends at Cougar Dam, Oregon, 1950–2100. ....	50
Figure 3-44. McKenzie River at Cougar Dam, Oregon Summary Hydrographs.....	51
Figure 3-45. Blue River Dam, Oregon Summary Hydrographs.....	52
Figure 3-46. Cougar Dam, Oregon Annual Very High Fire Danger Days.....	54
Figure 3-47. Middle Fork Willamette River Subbasin.....	55
Figure 3-48. Average Annual Temperature Trends at Hills Creek Dam, Oregon, 1950– 2100.....	56
Figure 3-49. Average Annual Summer Temperature Trends at Hills Creek Dam, Oregon, 1950–2100. ....	57
Figure 3-50. Average Annual Temperature Trends at Lookout Point Dam, Oregon, 1950–2100. ....	57
Figure 3-51. Average Annual Summer Temperature Trends at Lookout Point Dam, Oregon, 1950–2100. ....	58
Figure 3-52. Median Winter Precipitation Trends at Hills Creek Dam, Oregon, 1950– 2100.....	58
Figure 3-53. Median Summer Precipitation Trends at Hills Creek Dam, Oregon, 1950– 2100.....	59
Figure 3-54. MF Willamette River at Hills Creek Dam, Oregon Summary Hydrographs.....	60
Figure 3-55. Fall Creek Dam, Oregon Summary Hydrographs.....	61
Figure 3-56. MF Willamette River at Lookout Point Dam, Oregon Summary Hydrographs.....	62
Figure 3-57. Lookout Point Dam, Oregon Annual Very High Fire Danger Days.....	64

*Willamette Valley System Operations and Maintenance  
Environmental Impact Statement*

Figure 3-58. Coast Fork Willamette River Subbasin. .... 65

Figure 3-59. Average Annual Temperature Trends at Cottage Grove Dam, Oregon,  
1950–2100. .... 66

Figure 3-60. Average Annual Summer Temperature Trends at Cottage Grove Dam,  
Oregon..... 66

Figure 3-61. Median Winter Precipitation Trends at Cottage Grove Dam, Oregon..... 67

Figure 3-62. Median Summer Precipitation Trends at Cottage Grove Dam, Oregon..... 67

Figure 3-63. Coast Fork Willamette River at Cottage Grove Dam, Oregon Summary  
Hydrographs..... 69

Figure 3-64. Row River at Dorena Dam, Oregon Summary Hydrographs. .... 70

Figure 3-65. Dorena Dam, Oregon Annual Very High Fire Danger Days. .... 72

Figure 3-66. Long Tom River Subbasin..... 73

Figure 3-67. Average Annual Temperature Trends at Fern Ridge Dam, Oregon. .... 74

Figure 3-68. Average Annual Summer Temperature Trends at Fern Ridge Dam, Oregon..... 74

Figure 3-69. Median Winter Precipitation Trends at Fern Ridge Dam, Oregon..... 75

Figure 3-70. Median Summer Precipitation Trends at Fern Ridge Dam, Oregon..... 75

Figure 3-71. Long Tom River at Fern Ridge Dam, Oregon Summary Hydrographs. .... 76

Figure 3-72. Fern Ridge Dam, Oregon Annual Very High Fire Danger Days. .... 77

**LIST OF TABLES**

Table 2-1. Relevant Climate Factors Analyzed by Resource..... 3

Table 3-1. Salem Flow Change..... 26

Table 3-2. Albany Flow Change..... 32

Table 3-3. Detroit Dam Flow Change..... 39

Table 3-4. Green Peter Dam Flow Change..... 46

Table 3-5. Cougar Dam Flow Change..... 53

Table 3-6. Blue River Dam Flow Change..... 53

Table 3-7. Hills Creek Dam Flow Change. .... 63

Table 3-8. Fall Creek Dam Flow Change..... 63

Table 3-9. Lookout Point Dam Flow Change..... 63

Table 3-10. Cottage Grove Dam Flow Change..... 71

Table 3-11. Dorena Dam Flow Change. .... 71

Table 3-12. Fern Ridge Dam Median Flow Change..... 77

## **1. INTRODUCTION**

This sub-appendix outlines additional climate change information used in the Willamette Valley System (WVS) Operations and Maintenance Environmental Impact Study (EIS). The supplemental information was used by the EIS Project Delivery Team (PDT) as they qualitatively assessed how changes in future hydroclimate may affect their resource areas and other likely impacts of concern.

USACE Northwest Division (NWD) and Portland District (NWP) have proactively conducted and been involved in regional climate change studies in the Pacific Northwest and Columbia River Basin (CRB). The result of these efforts has yielded comprehensive collections of highly useful reports and databases. In particular, the River Joint Operating Committee's RMJOC-II climate projection information was used as the basis for much of the discussion that follows. The RMJOC-II climate change planning studies and data have been used for recent efforts such as the Columbia River Treaty (CRT), Columbia River System Operations (CRSO) EIS, and Columbia Basin Water Management Hydrology. The Climate toolbox (CIRC 2020) (<https://climatetoolbox.org/>), a regional suite of assessment tools, was also used for EIS purposes to demonstrate comparative climate trend changes between different WVS sites and projects (project refers to dams and their associated reservoirs) over the historical as well as projected future years.

The Climate Change Toolbox was created by the University of California Merced and is supported by the National Oceanic and Atmospheric Administration (NOAA)-RISA, CIRC, NIDIS, the Northwest Climate Adaptation Science Center, and the USDA Northwest Climate Hub. Please note that the Climate Change Toolbox is "a collection of tools for addressing questions relating to climate monitoring, water resources, fire conditions, forecasts, and projections." The tool also includes output directed at "addressing questions relating to agriculture." The Climate Change Toolbox relies upon projections from a variety of climate and downscaled hydrologic datasets. From the tool's metadata file, the following tool background information and context is given:

The 20 climate models and 2 scenarios (Representative Concentration Pathways (RCP) 4.5 and 8.5) were downscaled to an approximately 4-km resolution across the U.S. for compatibility with the gridMET data and the tool itself.

Hydrology projections from 10 global climate models (GCMs) and 2 scenarios were simulated using the Variable Infiltration Capacity (VIC v 4.1.1.2) hydrology model, forced with the downscaled MACAv2-Livneh data 1950–2005 (historical) and 2006–2100 (future) to 1/16th degree to produce metrics such as snow water equivalent, soil moisture, runoff, and evaporation. The climate data was downscaled using gridded historical observations of meteorology from Livneh (v13 for USA and v14 for British Columbia, Canada).

A smaller ensemble of GCMs will result in less definition of the true model variability and uncertainty. This resolution is still useful for inferring future hydroclimate and hydraulic trend direction through the 21st century. Due to an incomplete probability description due to a small ensemble, the PDT is cautioned not to use specific numerical results from the toolbox. The Climate Toolbox and RMJOC-II study data were developed separately, albeit from similar Coupled Model Intercomparison Project 5 (CMIP5) and GCM scenario datasets. The tool and the RMJOC studies used data generated from the CMIP5, but each provides information not provided by the other. Additional information concerning Climate Change Toolbox outputs can be found at the [climatetoolbox.org](http://climatetoolbox.org) link provided above.

## **2. RELEVANT CLIMATE CHANGE FACTORS**

The WVS EIS PDT identified early in the process which climate factors were likely most applicable to the National Environmental Policy Act (NEPA) EIS analysis. Their importance and relevance were evaluated with respect to EIS analysis areas and focused on the most consequential resource areas and impacts to alternatives of the EIS. The relevant climate change factors are listed below. USACE PDT refined the list of climate factors that were relevant to the WVS EIS climate change analysis. Each resource topic analysis used the climate change assessment as the basis of a qualitative analysis of relevant climate change factors, as shown in Table 2-1.

The nine relevant climate change factors are:

1. Ambient air temperature changes.
2. Water temperature changes.
3. Precipitation changes.
4. Seasonal timing of flow peaks and volumes.
5. Low summer flow—shortage/volume/frequency.
6. Change in snowpack accumulation and spring freshet timing.
7. Reservoir evaporation/reach evapotranspiration effects.
8. Wildfire intensity/frequency changes.
9. Wildfire impacts to water quality.

*Willamette Valley System Operations and Maintenance  
Environmental Impact Statement*

**Table 2-1. Relevant Climate Factors Analyzed by Resource.**

Resource Topic	Ambient temp (1)	Water temp (2)	Precipitation (3)	Flow peak and timing (4)	Summer low flow (5)	Spring snow melt (6)	Evapotranspiration (7)	Wildfire (8)	Wildfire effects (9)
Hydrologic Processes	-	-	X	X	X	X	X	-	-
River Mechanics and Geomorphology	-	-	-	X	-	X	-	X	-
Geology and Soils	-	-	-	-	-	-	-	-	-
Water Quality	X	X	X	X	X	X	X	X	X
Vegetation (including ESA/sensitive species and critical habitat)	X	X	X	X	X	X	X	X	X
Wetlands	X		X	X	X	X	X		X
Fish, Aquatic Invertebrates, and Aquatic Habitat (including ESA/sensitive species and critical habitat)	X	X	X	X	X	X	X	X	X
Wildlife, Birds, and Terrestrial Habitat (including ESA/sensitive species and critical habitat)	X	X	X	X	X	X	X	X	X
Air Quality	X	-	-	-	-	-	-	X	-
Socioeconomics	X	X	X	X	X	X	X	X	X
Power and Transmission	X	-	X	X	X	X	X	-	-
Water Supply (Irrigation, Municipal, and Industrial)	-	-	X	X	X	-	-	-	-
Recreation	X	X	X	X	X	X	X	X	X
Land Use	-	-	-	-	X	-	-	X	-
Hazardous Materials	X	-	X	-	X	-	-	X	-
Public Health and Safety – Hazardous Algal Blooms	-	X	X	X	X	-	X	-	X
Public Health and Safety – Hazardous Materials	-	-	X	-	-	-	-	X	-
Public Health and Safety – Drinking Water	-	-	X	X	X	X	X	-	X
Environmental Justice	X	X	X	X	X	X	X	X	X
Cultural Resources	-	-	-	X	X	-	-	X	-
Visual Resources	-	X	X	X	X	X	X	X	X
Noise	-	-	-	-	-	-	-	X	-
Tribal Resources	X	X	X	X	X	X	X	X	X

The relevant hydroclimate variables, with the exception of wildfire intensity, reflect the operations and maintenance -centric metrics of the EIS. The wildfire element of the list below is indicative of likely impacts on future post-fire runoff response and water quality-related issues that will likely be experienced in the future. Wildfire could also impact additional operations areas, such as disrupting power transmission, water supply (e.g., pumping etc.), etc.

### **3. SUPPLEMENTAL DATA SOURCES**

The RMJOC-II and derivative Columbia River Basin (CRB) climate studies characterize the current period as well as expected future climate trends in the Pacific Northwest, including the Willamette Valley. The RMJOC-II information discussed below is a planning-level product. That is, while suitable for evaluating relative difference analyses, for example, ensemble median change between baseline, historical period, future epochs, etc., it was not “designed” to support reservoir routing modeling in watersheds like the Willamette River. In discussions with PDT modelers and in coordination with USACE Vertical Team Alignment Memorandum (VTAM), vertical alignment consensus was reached on the determination of the “actionability” of the RMJOC-II and CMIP5 streamflow datasets for reservoir routing, including water temperature modeling uses in this EIS. The consensus was that the datasets did not support the quantitative modeling requirements and was not actionable for these purposes. The dataset usage was hindered by bias correction and GCM downscaling model accuracy and uncertainty as well as the inherent shorter travel times in the Willamette River Basin itself. Variable Infiltration Capacity (VIC) is flow routing model performance, which the subject stream dataset depends on, is better in large basins but not as skilled in smaller subbasins. For this and other technical reasons, it was not appropriate to use RMJOC-II-generated future period of record streamflow for quantitative (e.g., hydro-regulation) modeling or as a definitive way to assess final climate projection impacts to WVS EIS alternatives. The RMJOC-II reports are on the following websites:

<https://usace.contentdm.oclc.org/utis/getfile/collection/p266001coll1/id/10562>

<https://usace.contentdm.oclc.org/digital/collection/p266001coll1/id/9936/rec/1>

The Climate Toolbox data visualization tools (<https://climatetoolbox.org/climate>) are useful for making qualitative determinations about how relevant climate factors are likely to change. The Climate Change Toolbox was created by the University of California Merced and is supported by NOAA-RISA, CIRC, NIDIS, the Northwest Climate Adaptation Science Center, and the USDA Northwest Climate Hub. The Climate Change Toolbox consists of a collection of web tools for visualizing past and projected climate and hydrology of the contiguous United States. The tool provides the user with extensive options for site selection (includes all sites of interest for the WVS EIS) as well as a robust range of climate change hydroclimate and hydrology variables that can be statistically summarized. The user can easily generate an extensive climate report, contrasting historical baselines to future year climate change scenarios of interest. The Climate Change Toolbox relies upon projections from a variety of climate and downscaled hydrologic

datasets. From the tool's metadata file, the following tool background information and context is given:

The 20 climate models and 2 scenarios (RCP 4.5 and 8.5) were downscaled to an approximately 4-km resolution across the U.S. for compatibility with the gridMET data and the tool itself.

Hydrology projections from 10 global climate models (GCMs) and 2 scenarios were simulated using the Variable Infiltration Capacity (VIC v 4.1.1.2) hydrology model, forced with the downscaled MACAv2-Livneh data 1950–2005 (historical) and 2006–2100 (future) to 1/16th degree to produce metrics such as snow water equivalent, soil moisture, runoff, and evaporation. The climate data was downscaled using gridded historical observations of meteorology from Livneh (v13 for USA and v14 for British Columbia, Canada).

For these reasons, the tool and its results were found very useful for supplementing PDT understanding of likely climate change trends in the Willamette Valley. There are important considerations to keep in mind when using the Climate Toolbox. First, the tool utilizes nine global circulation models (GCMs) as the basis for future change projections synthesized by the tool. In comparison, the RMJOC-II streamflow ensemble dataset is composed of 160 GCM scenarios. "It is USACE policy to use the hydrologic projections from the full ensemble CMIP5 model outputs to capture the range of potential future hydrologic conditions within a basin, as at this time there is no justification for selecting only a subset of models" (RMJOC 2018). While the Toolbox can be useful for qualitative comparisons, it would be erroneous to explicitly compare RMJOC-II and the Climate Toolbox results.

### **3.1 Overview of RMJOC-II Climate Change Projections**

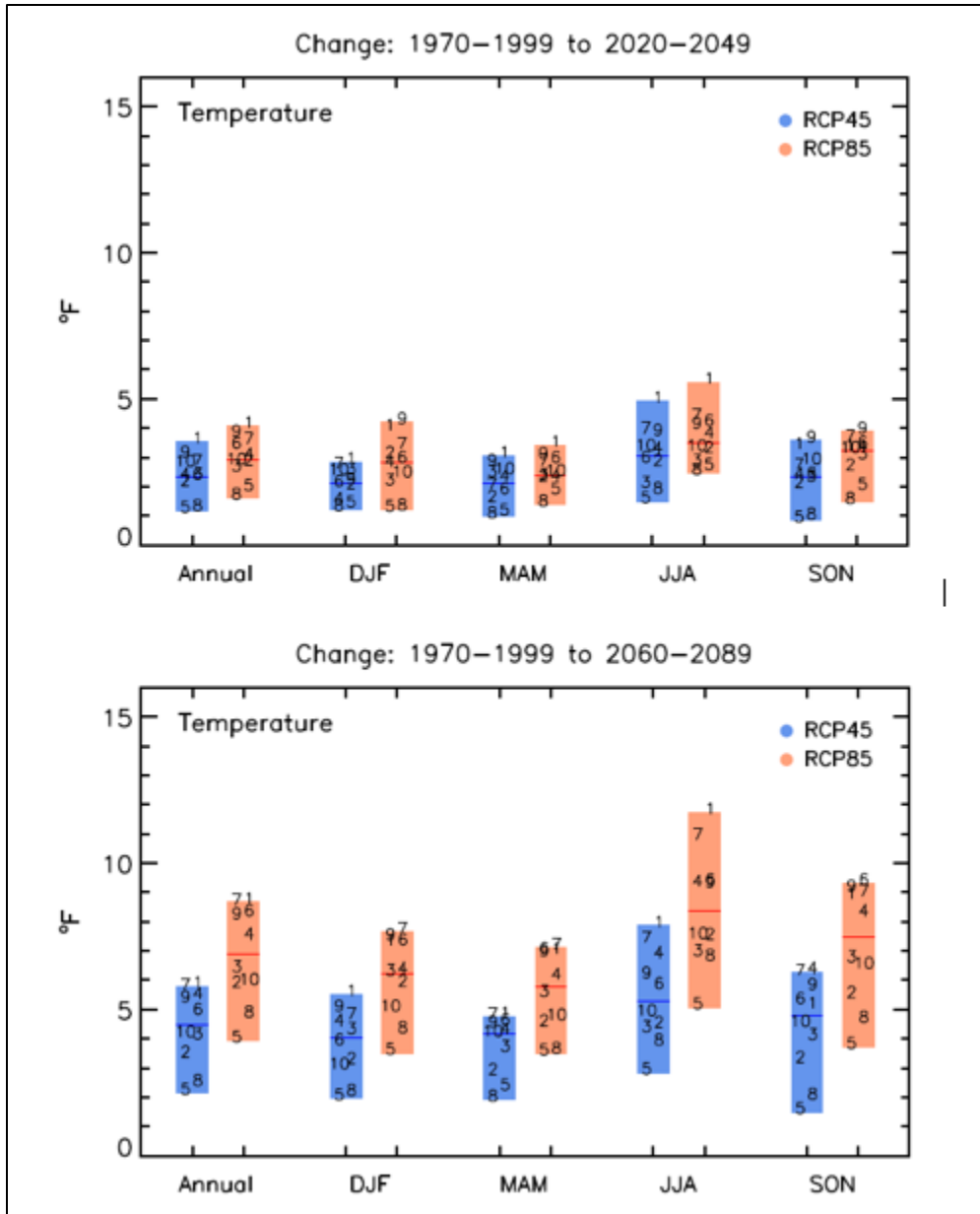
The primary basis for climate change projections discussed in the following sections of this appendix are derived from the RMJOC-II study Parts I and II (RMJOC 2018; RMJOC 2020). RMJOC-II hydroclimate change trends have been used in follow-on climate change studies in the CRB such as Columbia River Treaty studies (CRT 2021) and the Columbia River System Operations Environmental Impact Statement (CRSO EIS) (USACE et al. 2020). These synthesized qualitative determinations and interpretations included trends in projected temperature, precipitation, snowpack, and naturalized streamflow. These unregulated drivers and flow metrics are documented in the RMJOC-II Part I (2018). This study represents the most recent and best available technical information for future climate change in the Columbia River Basin, including the Willamette Valley.

Part II of the RMJOC-II studies (2020) focused on regulation modeling results in the major subbasins of the Columbia River Basin. Current regulation operations modeling was not undertaken for the Willamette River Basin. Detailed reasoning for the decision is contained in RMJOC-II Part II (RMJOC 2020). Future projection flows were found to be an unreliable

representation of future flow conditions. Use of these flows in regulation modeling would likely lead to high uncertainty in the modeling results.

### **3.1.1 Temperature**

The region is warming, and projections indicate that this trend will likely accelerate. Over the historical period (1990–1999), temperatures have increased and are expected to increase (U.S. Global Change Research Program [USGCRP] 2017; River Management Joint Operating Committee [RMJOC] 2018). Temperatures in the region have warmed about 1.5 degrees Fahrenheit (F) since the 1970s. They are expected to warm relative to the historical period 1970–1999 by another 1.5°F to 3°F by the 2030s (WYs 2020 through 2049) and 2°F to 5°F by the 2070s (WYs 2060 through 2089). Warming is projected to be greatest in the Willamette Valley floor lowland areas (e.g., I-5 corridor) during the summer. Higher elevation areas such as the Cascades and Coast ranges could experience somewhat lower warming rates. Figure 3-1 displays Willamette Valley ambient (air) temperature projections from RMJOC-II Part I. GCM scenario projections (numbers in the bar plot) are relative to the historical baseline period, 1970 through 1999. Annual and seasonal median shifts were highest under the RCP 8.5 GCM scenarios.

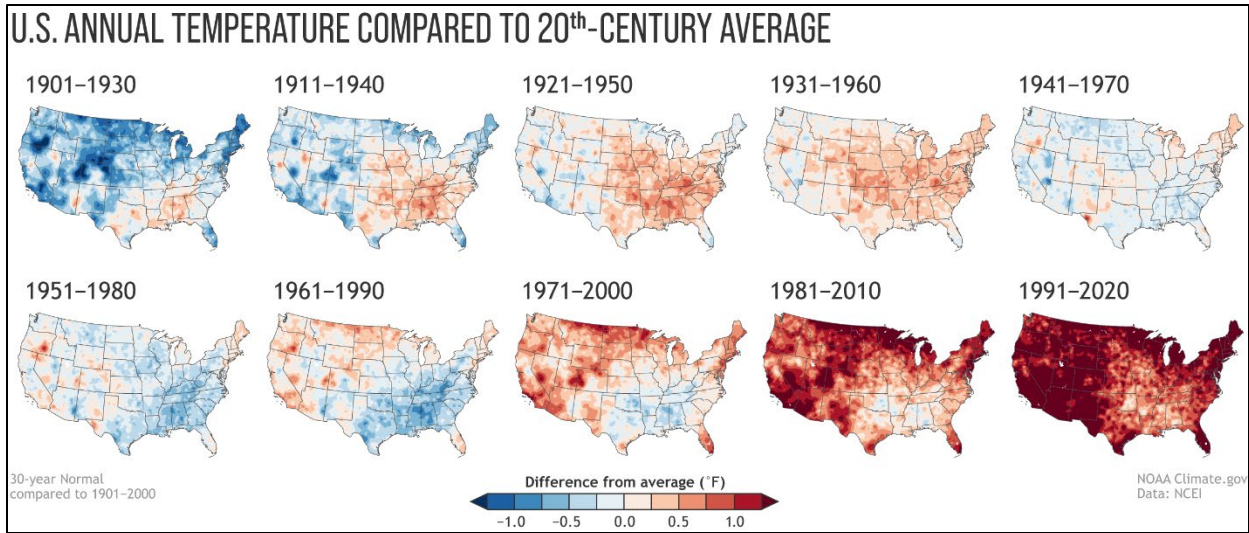


**Figure 3-1. Projected Willamette River Basin Average Temperature Change (RMJOC 2018).**

Recent years (2000 through present) are, on average, warmer compared to 1970 through 1999. NOAA published revised “climate normals” for historical years:

<https://www.climate.gov/news-features/understanding-climate/climate-change-and-1991-2020-us-climate-normals> (current as of April 2022).

Figure 3-2 displays NOAA annual observed temperature changes (NOAA 2021).



**Figure 3-2. NOAA Annual Observed Temperatures.**

Source: <https://www.climate.gov/media/13467>

Regionwide warming is expected to increase into the future, continuing the trends shown above. Although ambient temperature increase is a primary driver of other hydroclimate variables, corresponding changes in temperature are not linearly translated.

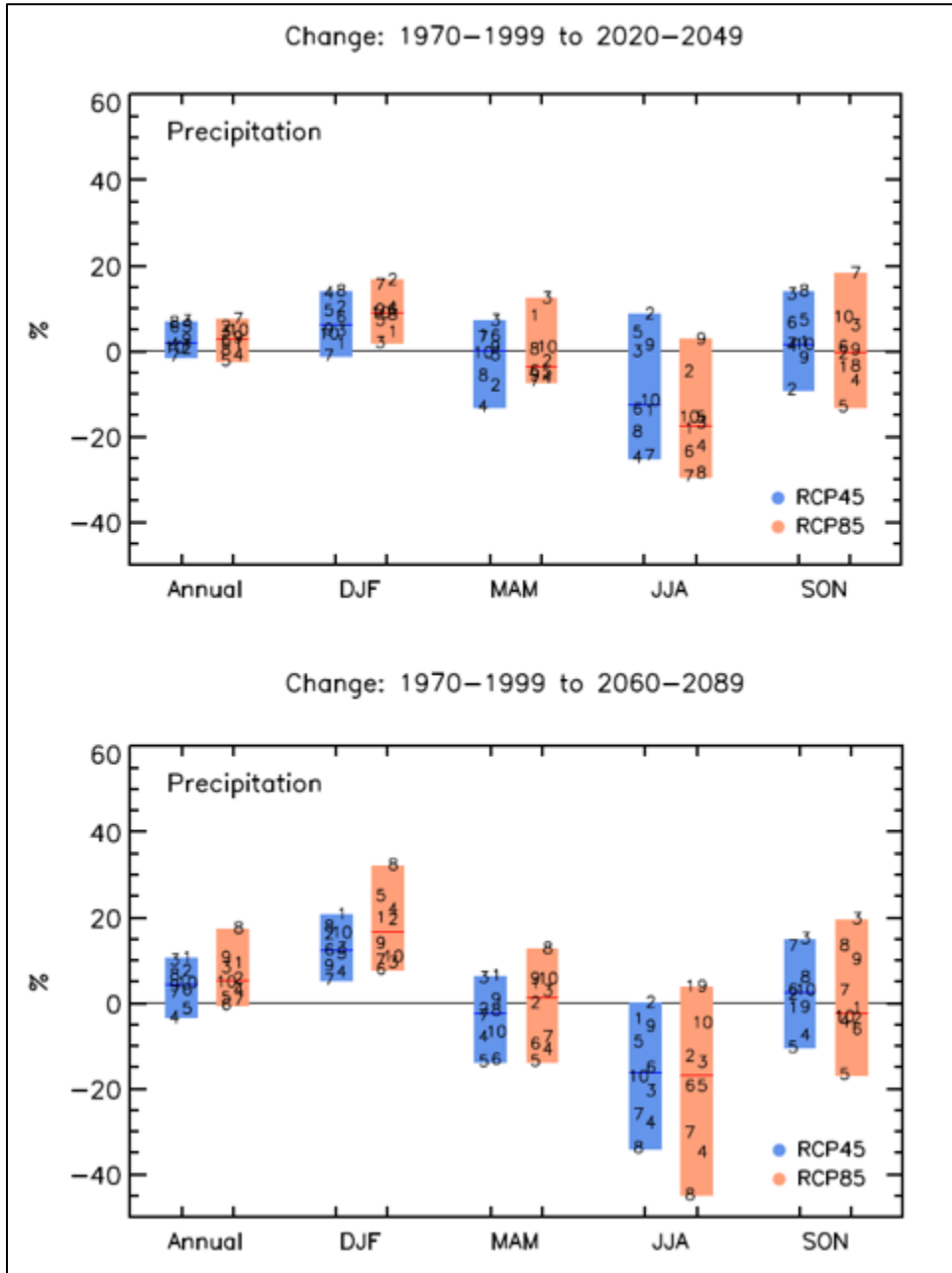
For example, an increase in annual temperatures may not translate to streamflow change in similar directions or percent magnitudes. The hydrologic system is too complex to make highly predictable and certain forecasts. Future projection uncertainty increases dramatically further out into the century. The precise degree to which temperatures will increase is clouded and specific determinations are highly uncertain at this time. Although it is desirable to have quantifiable future temperature data for EIS determinations, it is cautioned that the climate change information available at this time does not support that level of precision for the Willamette Valley.

### 3.1.2 Precipitation

RMJOC-II Part II (2018) found that observed precipitation trends are less certain than observed temperature trends (Figure 3-3). However, across both RCP 4.5 and RCP 8.5, the majority of GCMs project marginal increases in annual precipitation. More operationally substantial changes are projected to occur seasonally, with the largest increases in the winter months, December through February (DJF), and decreases in the summer months, June through August (JJA). Trends in the RMJOC II are for the entire CRB but were determined at The Dalles, OR. The Dalles is a primary system computational control point (CCP) for Northwest Division water management. The general trends are similar for the Willamette Valley. Although the median trend derived based on the full ensemble at The Dalles is consistent with the median trends found throughout the CRB, including for the Willamette River Subbasin, the range of GCM outputs varies considerably throughout the CRB.

*Willamette Valley System Operations and Maintenance  
Environmental Impact Statement*

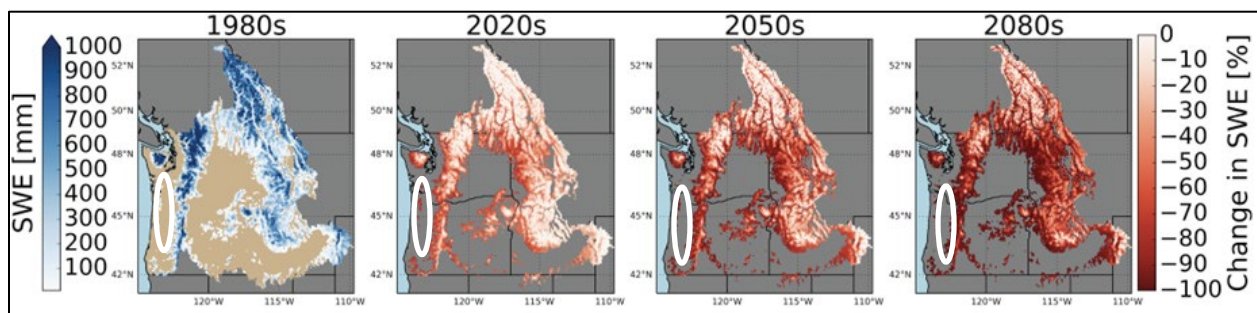
Caution interpreting future trends is warranted. The study (RMJOC 2018) identified high interannual variability in the observed datasets. Higher interannual variability in observed datasets could translate to more model uncertainty in projections. Further, the warmest or driest GCMs at The Dalles may not be the same in all subbasins. To capture the uncertainty associated with projected hydrometeorological outputs derived based on GCMs, it is important to consider the range of model outputs, which is best captured by using a large ensemble set as was adopted as part of the RMJOC study.



**Figure 3-3. Projected Willamette River Basin Average Precipitation Change (RMJOC 2018).**

### 3.1.3 Snow Water Equivalent (SWE)

Winter snowpack is very likely to decline over time as more winter precipitation falls as rain instead of snow. The general trend across the Willamette River Basin is for a decrease in most medium to low elevation subbasins. In the Willamette River Basin, the forecast is for near total reduction of annual snowpack toward the end of 21st century (RMJOC 2018). Figure 3-4 depicts Columbia River Basin (the Willamette Valley is denoted via white circles) Snow Water Equivalent (SWE) in the 1980s and average SWE changes by the 2020s (2010–2039), 2050s (2040–2069), and 2080s (2070–2099) on April 1 for the 10 GCMs using RCP 8.5 and downscaled via Bias Corrected and Spatial Downscaling (BCSD). Areas in tan historically have less than 10 mm of snow water equivalent (RMJOC 2018). The RMJOC-II streamflow ensemble dataset is composed of 160 GCM scenarios.



**Figure 3-4. Projected Willamette River Basin Average Snow Water Equivalent (RMJOC 2018).**

SWE drives runoff patterns as well as streamflow temperatures. However, the complexity of correlating the water temperature response to the flow changes driven by snow melt runoff is not accurate. Caution should be exercised when attempting to extrapolate SWE projections of future water temperatures. For this reason, the WVS EIS climate change assessment primarily focuses on SWE as a major component driving the historical spring freshet (spring snow melt), rather than its impact on water temperature. In the near term, it is likely that the spring freshet will occur earlier but will decrease to near 100 percent reduction by the end of the century.

### 3.1.4 Naturalized Streamflow

The most downstream portion of the Willamette River considered in the WVS EIS is at Willamette Falls, which is situated adjacent to Oregon City, OR. The Cascade Range basins are tributary to the Willamette River. The primary driver of runoff in the Cascade Range basins is rainfall. Rainfall has been the primary contributor to peak annual runoff response throughout the Willamette River Basin historically. The spring freshet is still an important contributor to high flow peaks and volumes later in the water year. The annual maximum runoff occurs in the winter months (DJF). Historically, there has been a small spring freshet as snowmelt swells streams starting April 1st to May 1st. Future projections point to near elimination of the snow-driven freshets as higher ambient temperatures take hold in the Willamette Valley (RMJOC 2018). The overall projection is for median increases of winter flows and volumes with decreasing late spring and summer flows (Figure 3-5).

Willamette Valley System Operations and Maintenance  
Environmental Impact Statement

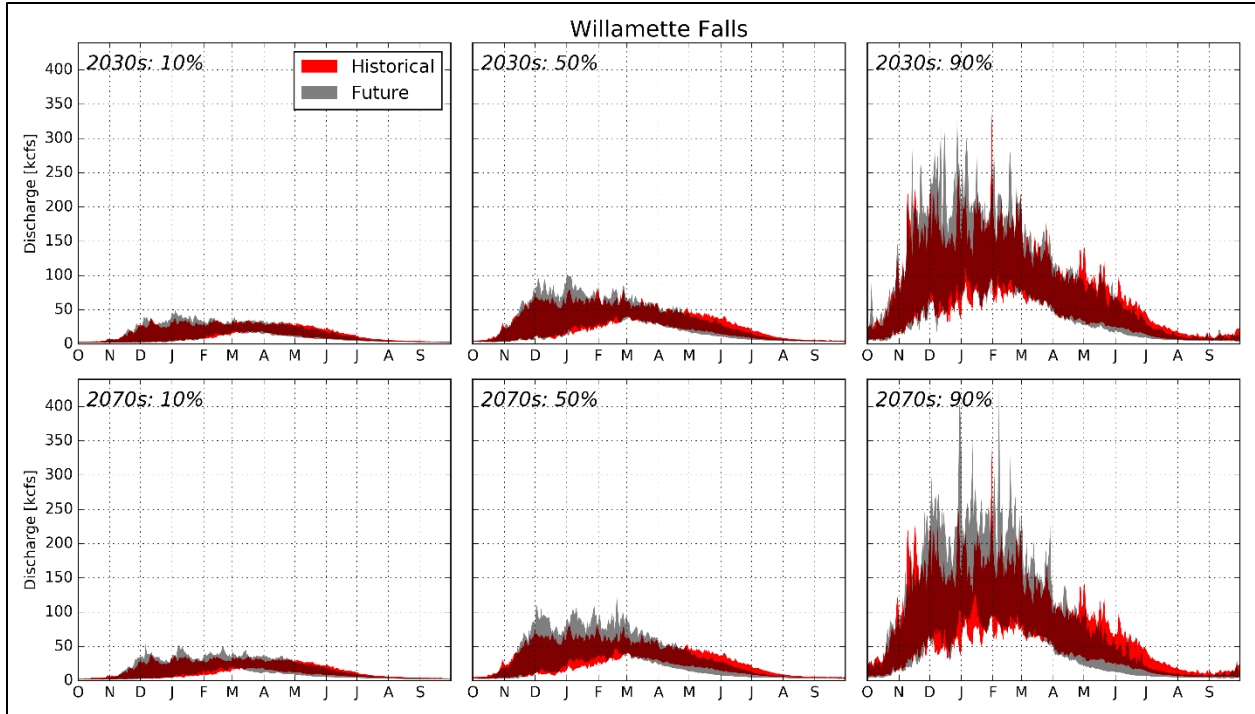


Figure 3-5. Projected Willamette River Basin Average Naturalized Streamflows (RMJOC 2018).

### 3.1.5 Wildfire

The Fourth Climate Change Assessment (Chapter 24, Pacific Northwest), prepared by the U.S. Global Change Research Program, indicated that wildfires are increasing and other changes are clear signs of a warming planet (USGCRP 2018).

Climate change is expected to increase the frequency and/or intensity of many extreme events that affect infrastructure in the Northwest. Available vulnerability assessments for infrastructure show the prominent role that future extremes play. Since much of the existing infrastructure was designed and is managed for an unchanging climate, changes in the frequency and intensity of flooding, drought, wildfire, and heat waves affect the reliability of water, transportation, and energy services (USGCRP 2018).

Warmer winters have led to reductions in the mountain snowpack, increasing wildfire risk (Chapter 6, USGCRP 2018). Existing water, transportation, and energy infrastructure already face challenges from flooding, landslides, drought, wildfire, and heat waves. Climate change is projected to increase the risks from many of these extreme events (Key Message 3, USGCRP 2018). The Sixth Oregon Climate Assessment notes that the total annual area burned in Oregon has increased during the last 35 years (OCCRI 2023).

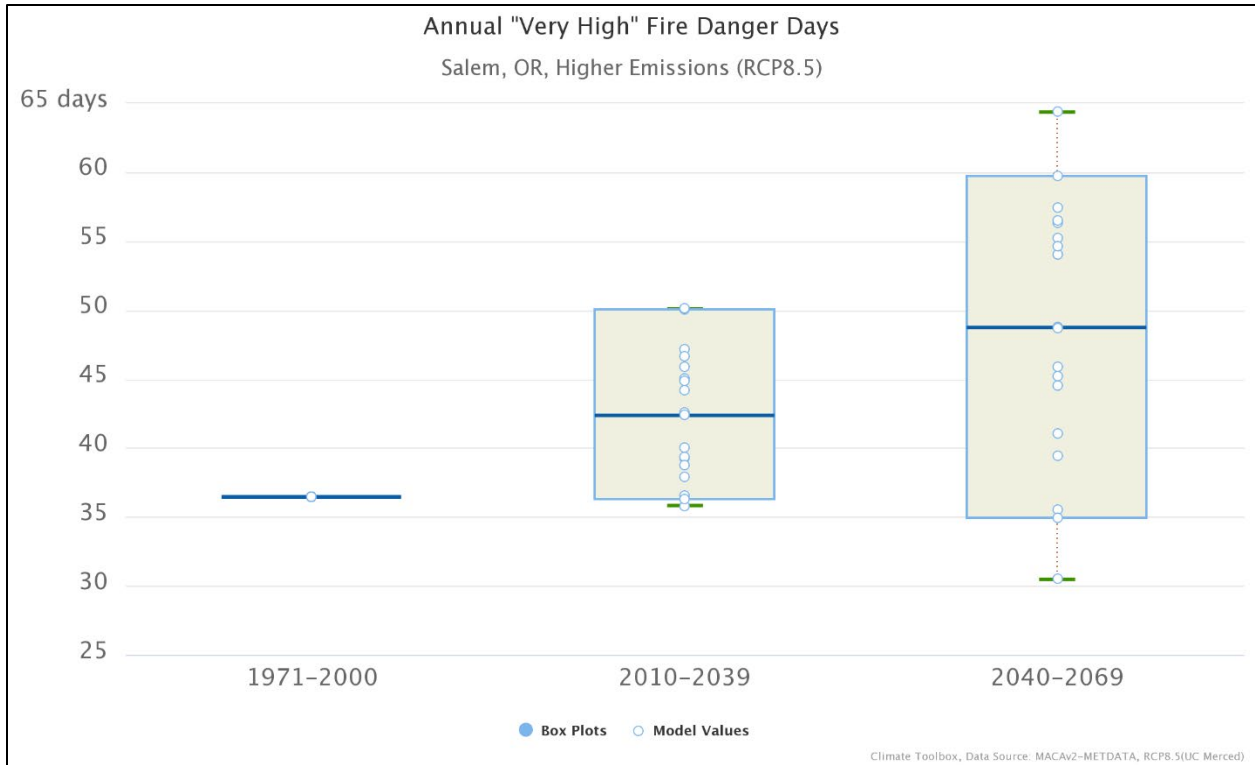
In late summer and autumn and prior to the onset of the autumn rains, particularly strong and dry easterly winds, known colloquially as east winds, promote the rapid spread of wildfire. East winds were key drivers of the

*Willamette Valley System Operations and Maintenance  
Environmental Impact Statement*

largest wildfires on record in western Oregon, including the 2020 Labor Day fires (Abatzoglou et al. 2021, Mass et al. 2021, Reilly et al. 2022). Despite recent advances, understanding of how anthropogenic emissions may affect local winds in Oregon remains limited. Due to their coarse spatial resolution, global climate models and all but the highest-resolution regional climate models cannot adequately simulate mountain slope and valley winds, coastal winds, sea breezes, and winds associated with mesoscale convective systems (Doblas-Reyes et al. 2021). Large numbers of simulations from multiple high-resolution (1 to 10 km [0.6 to 6 mi]) regional climate models ultimately will be required to estimate, with high confidence, changes in these types of winds across Oregon (OCCRI, 2023).

The Willamette River Basin experienced historic wildfires in September 2020 (Abatzoglou et al. 2021). The fires reached the suburbs of Portland, OR and air quality was greatly diminished by smoke and burn particulates. Health impacts to the residents of the Portland and adjacent communities were severe. The wildfire event itself was driven by an unusual concurrence of dry and windy weather conditions. A large blocking low pressure front over Idaho and southern Canada drove unusually high and sustained winds into the Willamette Valley. This occurred after an above average hot and dry summer (Abatzoglou et al. 2021). Whether these conditions were accentuated by climate change trends and whether this pattern could become more frequent in the future remains a question. Climate change modeling does predict increasing fire risk days in the future (Climate Toolbox 2022).

The resulting fire intensity, damages, and loss of life added urgency to consideration of changes in future hydroclimate conditions that may in turn drive future wildfire intensity and frequency. Other post-fire impacts are relevant to the WVS. Changing runoff on terrain denuded and glazed to higher imperviousness could conceivably create higher peak flow events and increase sediment transport. These changes could have an unpredictable and high degree of impact to water quality and aquatic health. Re-deposition of sediment could increase operations and maintenance costs and alter the effectiveness of current water supply infrastructure (e.g., intakes), etc.



**Figure 3-6. Salem, Oregon Annual Very High Fire Danger Days.**

While Salem is not historically a location of high fire risk, Figure 3-6 does provide the trend direction of wildfire risk through the end of the century. The figure shows an increase in median annual "very high" fire danger days and the variability between GCM scenario projections are portrayed. Below are excerpts that further summarize wildfire impacts and post-fire hydrologic sediment and runoff response in the basin (from Section 4.3 River Mechanics and Geomorphology):

Climate change (RFFA 9) would increase winter inflows and sediment supply to the WRB, both upstream and downstream of the WVS dams and reservoirs. Additionally, there is a causal relationship between wildfires and increased sediment supply (Alden Research Laboratory, Inc. 2021). Expected increases in high fire risk days and associated increases in forest fire acreages are expected to increase WRB sediment yields due to climate change. Reservoirs act as sediment traps and would partially mitigate increases in sediment supply in regulated reaches. Additionally, climate change generally decreases conservation season flows and, therefore, conservation season reservoir stages (Section 4.2, Hydrologic Processes). This could increase bank exposure, decrease reservoir storage, and increase fine grained suspended sediment concentrations in the reservoirs and sediment releases downstream. As climate change does not increase operational range, but only stages within the operational range, this conservation season change is expected to be negligible to minor (Section

3.3.2.1.5, Climate Change). Effects would be additive with the other RFFAs within their respective seasons.

### **3.1.6 Invasive Species**

The Willamette River Basin is sensitive to all the above projected climate trends. There is concern that future climate change effects may induce or allow for greater expansion of non-native invasive species into the Willamette Valley aquatic and terrestrial environments (from Gervais et al. 2020):

Plants were the best-represented taxonomic group in these studies, and a variety of invasive plants are predicted to expand their ranges (e.g., McDonald et al. 2009; Chapman et al. 2014; Brummer et al. 2016). That being said, where spatially downscaled predictions are available, dynamics of invasive plants in the PNW itself are likely to be highly variable both within and between species (e.g., Bradley et al. 2009).

As the effects of climate change become clearer, the subject of invasives and their correlation with changing climate should be re-evaluated.

### **3.2 Climate Change in the Willamette River Subbasins**

Climate change is regional in scope and extent. Therefore, this WVS EIS assesses the climate change affected environment in terms of the whole Willamette River Basin. The study extents with subbasin delineation are shown below in Figure 3-7. The WVS EIS spatial focus was on the 13 Corps projects shown.

Willamette Valley System Operations and Maintenance  
Environmental Impact Statement

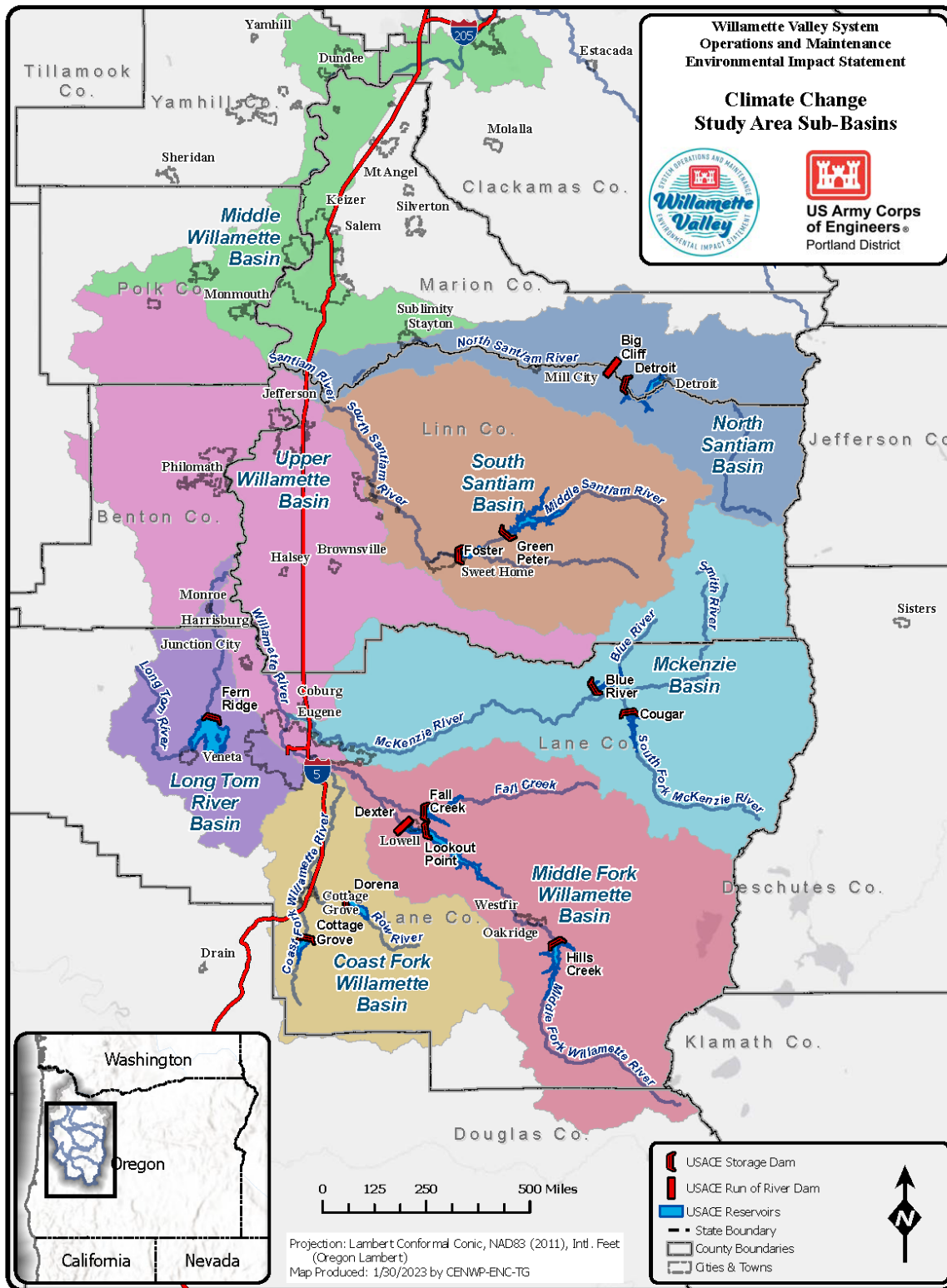


Figure 3-7. Willamette River Basin Subbasins.

*Willamette Valley System Operations and Maintenance  
Environmental Impact Statement*

The WVS is divided into two primary areas, the Middle and Upper Willamette River Basins. The Middle Willamette includes the mainstem Willamette River from Willamette Falls at Oregon City, OR (RM 26.6) to the confluence with the Santiam River (RM 108). The Upper Willamette begins above RM 108, Santiam River confluence, and includes the following tributary basins:

- North and South Fork Santiam River
- McKenzie River
- Middle Fork Willamette River
- Coast Fork Willamette River
- Long Tom River basins.

### **3.2.1 Current Regulations**

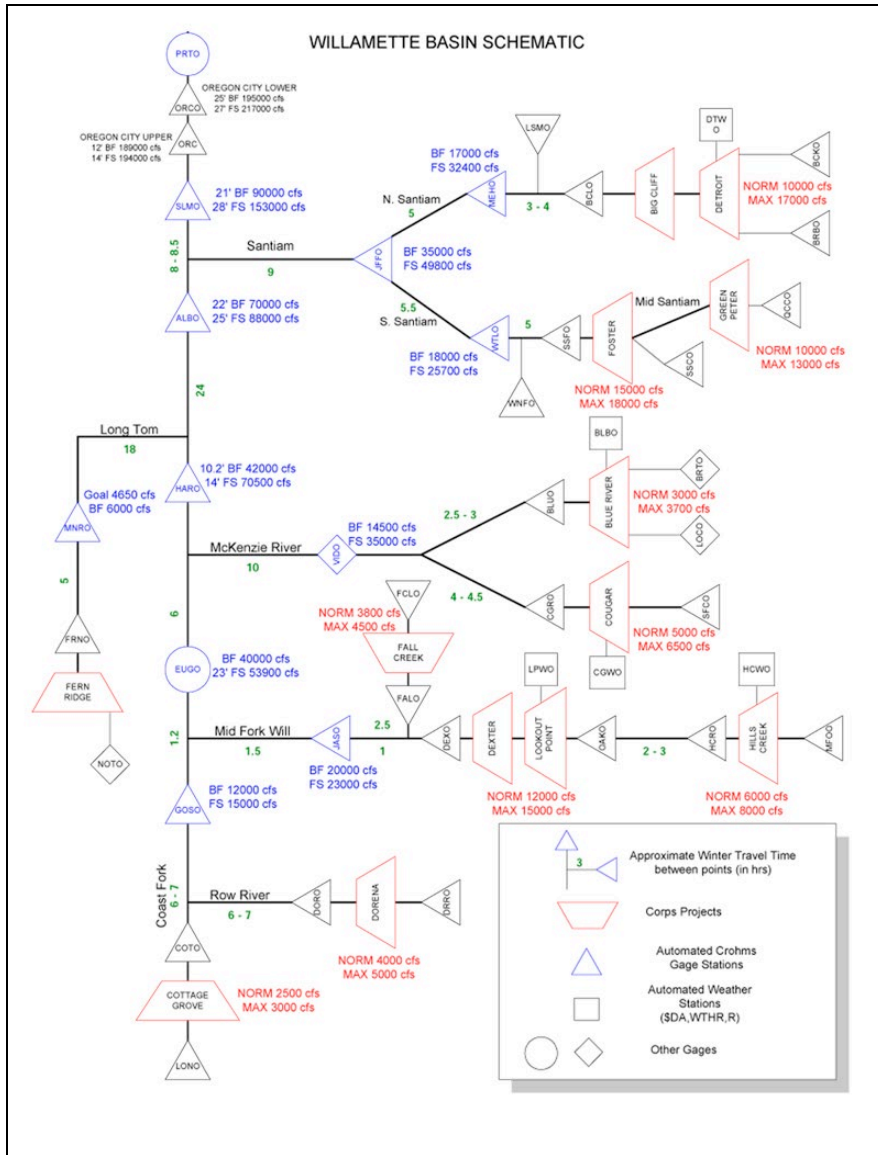
The dams are operated as a system with flood risk management being their primary purpose (Figure 3-8). In total, the dams control flows on six major tributaries affecting approximately 27 percent of the upstream watershed of Portland, OR. USACE Willamette Valley System storage projects are operated at or below the rule curve unless regulating to a highwater event. The rule curve provides guidance to reservoir regulators on how to manage the storage in the reservoir to meet the multipurpose needs. The storage projects are typically drawn down (i.e., storage is evacuated) in the fall to provide space to store high runoff from winter rain events. When downstream control points reach bankfull flow, USACE project outflows are reduced to project minimums to reduce downstream flood impacts. Rain events cause the reservoirs to rise and then stored water is evacuated once the flood threat has passed. Flood peak reduction is constrained by the large unregulated area below Salem as well as limited flood space in the tributary reservoirs themselves. At the local scale, USACE operates dams in the tributaries to minimize downstream flooding at local points.

In the early spring, the reservoirs begin to capture some of the runoff to store water for use in the summer months. Some stored water may also be used in the late spring for fish flow augmentation during drier years.

The Willamette River Basin conservation season occurs from approximately May through November and is a time when water stored in the system is released for multiple uses, including biological resources, water quality, power generation, irrigation, municipal and industrial uses, and recreation. USACE, together with its partners and customers, determine the order of use for stored water among the various projects and often address environmental variables and other constraints to project operation using real-time adaptive management.

In the fall, the storage projects are drafted down to their minimum pool level in preparation for flood risk management operations, which occur primarily in December and January.

*Willamette Valley System Operations and Maintenance  
Environmental Impact Statement*



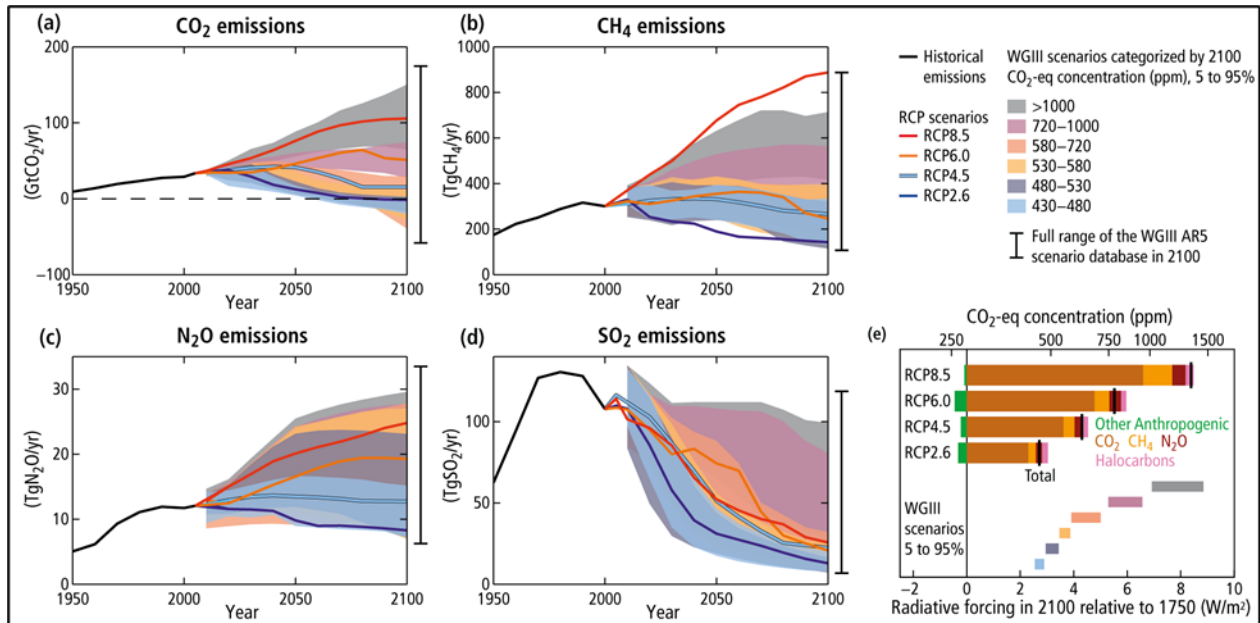
**Figure 3-8. WVS Regulation Schematic.**

Conceptually, operations could be changed to adapt to the shift in runoff timing. However, increase in winter flows cannot be used to meet summer demand. Maximum flood space is required during the winter months, especially considering projected future increases in winter volume. High water events that occur during refill cannot be stored above the existing rule curve elevations and therefore cannot be used to meet demand later in the season. Additional system storage would likely be required to benefit from higher winter and early spring inflows projected for the future.

### 3.2.2 Climate Change Projections

Future year climate change projections used are derived from the latest global climate model projections from the Intergovernmental Panel on Climate Change’s (IPCC’s) Fifth Assessment report (AR5) (IPCC 2022a).

This EIS study frames future scenarios in terms of two RCPs, RCP 4.5 and RCP 8.5, based on results generated in support of the RMJOC-II reports and results obtained from the Climate Toolbox. These two RCPs represent future scenarios for emissions of greenhouse gases. Figure 3-9 graphically summarizes the RCP scenarios. RCP 8.5 trends more extreme by 2100.



**Figure 3-9. IPCC Representative Concentration Pathways (RCPs).**

Source: [https://ar5-syr.ipcc.ch/topic\\_futurechanges.php](https://ar5-syr.ipcc.ch/topic_futurechanges.php)

Under current USACE guidance (e.g., ECB 2018-14 [USACE 2018]), the climate for which a project is designed can change over the full lifetime of that project and may affect its performance or impact operation and maintenance activities. USACE planning guidance recommends assuming a 100-year lifetime for major infrastructure. USACE climate change assessment period is recommended to extend up to 100 years. Often, the GCM datasets do not extend 100 years from a project completion date. This is the case here, and for the purposes of this EIS the climate change evaluation is through the end of the 21st century (year 2100).

### 3.2.3 Key to Summary Hydrograph Figures

Several summary flow hydrographs are presented below. They are derived from the RMJOC-II study analyses. The summary plots draw on disparate streamflow datasets and present the statistical distribution as box plots defined by median and quartile ranges. Figure 3-10 graphically depicts the summary hydrographs displayed below.

The RMJOC-II streamflow ensemble dataset is composed of 160 GCM scenarios. In Figure 3-10, the total GCM scenario set (160) is disaggregated and there are subsets of RCP 8.5 and RCP 4.5 (80 each). RCPs 4.5 and 8.5 are most often used for long-term planning studies; therefore, RCP 6.0- and RCP 2.6-based scenarios were excluded from this study.

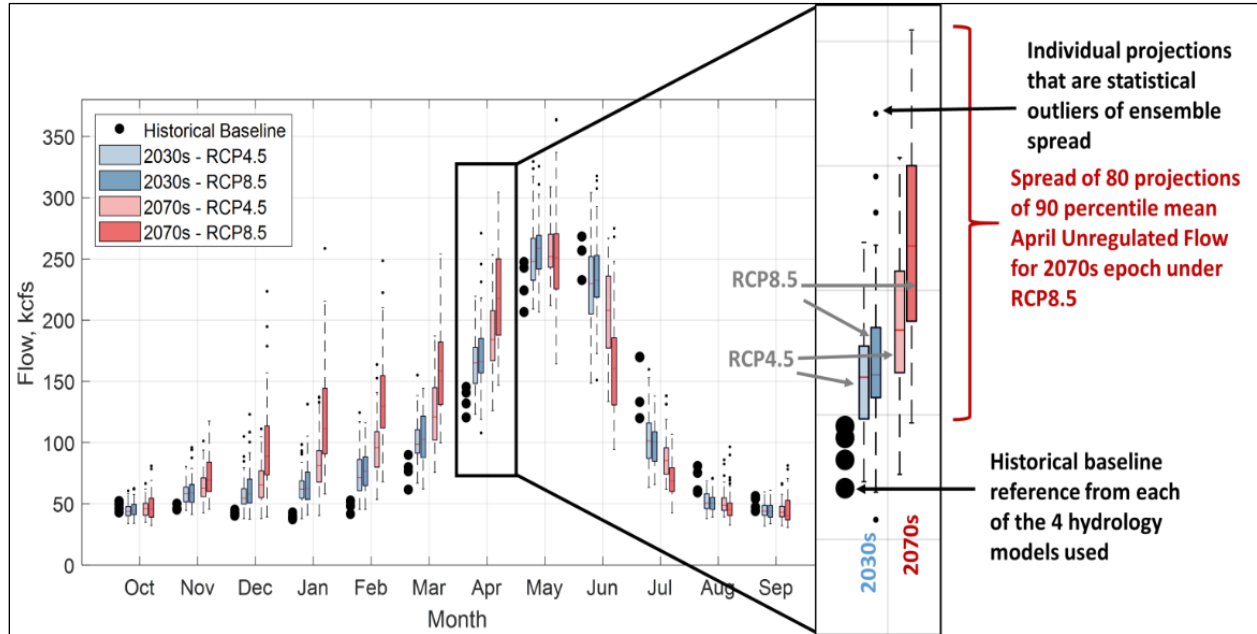


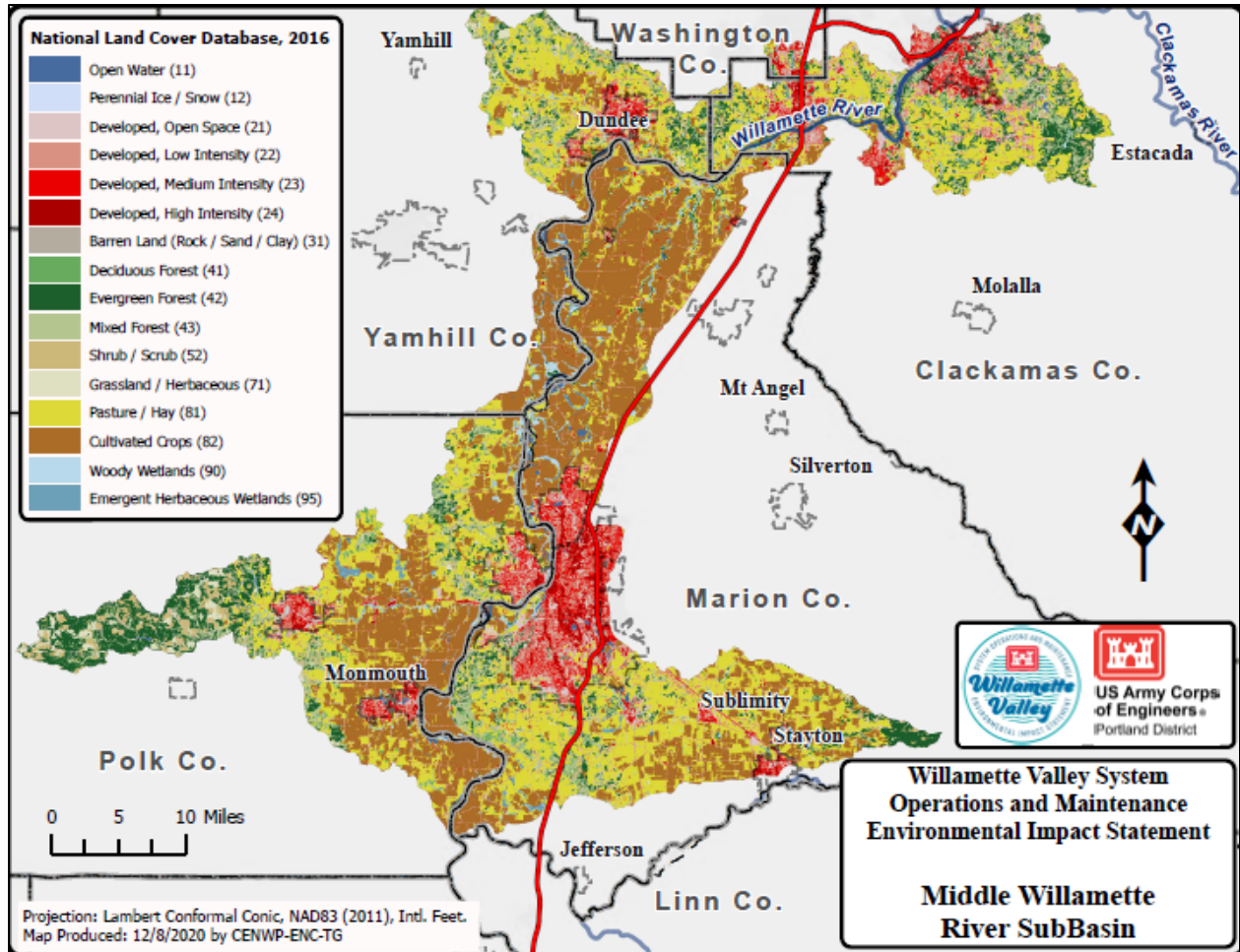
Figure 3-10. Example Historical and Future Predictions Graph.

### 3.2.4 Middle Willamette River

The Middle Willamette includes the mainstem Willamette River from Willamette Falls at Oregon City, OR (RM 26.6) to the confluence with the Santiam River (RM 108). Figure 3-11 graphically shows the basin delineation and major features, including land cover, as of 2016. Land cover shown in the appendix maps are included to serve as context for climate change impacts, especially impacts to the natural environment (i.e., the affected environment). The maps also include cities, towns, USACE dams and reservoirs, and transportation routes. Overall impacts to the affected environment are common to all habitats and USACE business lines under all alternatives, including the No-action Alternative.

Figure 3-11 is provided as context for the overall climate change impacts to the affected environment.

*Willamette Valley System Operations and Maintenance  
Environmental Impact Statement*



**Figure 3-11. Middle Willamette River Subbasin.**

This portion of the Basin contains the largest population centers outside of Portland, OR. The Salem/Keizer metro area is larger than the Eugene/Springfield metro area. The Basin is primarily low-lying valley floor. The mainstem Willamette River flows that reach the Middle Willamette River Subbasin are highly regulated due to upstream water management operations. Below Salem, local flows are primarily unregulated. Regulation has reduced flood peaks substantially while moderating low-flow conditions during the summer.

Relative to pre-dam conditions, Willamette Valley System regulation reduces peak high water during the winter flood season, November through March, and increases low summer flows. The WVS also makes thermal regulation possible through release of cooler reservoir outflows. Given that many climate change projections are for warmer conditions, increased winter volumes, and less baseflow in the summer, WVS project storage and regulation operations offer the opportunity to offset (to a degree) the potential negative impacts of climate change on the Basin’s climate change hydrology and hydroclimate trends of concern.

Figure 3-12 is derived from the Climate Toolbox. The figure graphically shows average annual temperatures trending upward with an increasing rapidity into the 21st century. At Salem, OR

*Willamette Valley System Operations and Maintenance  
Environmental Impact Statement*

in the Middle Willamette River Subbasin, the annual median temperature is projected to increase about +7.5°F from 2001 to 2100 or 2099, compared to the 1971–2000 baseline. Caution should be taken in applying these projections. The following Climate Toolbox figures can be used with confidence to identify the direction and relative scope of climate factor trends, but individual values should not be used as threshold or design values.

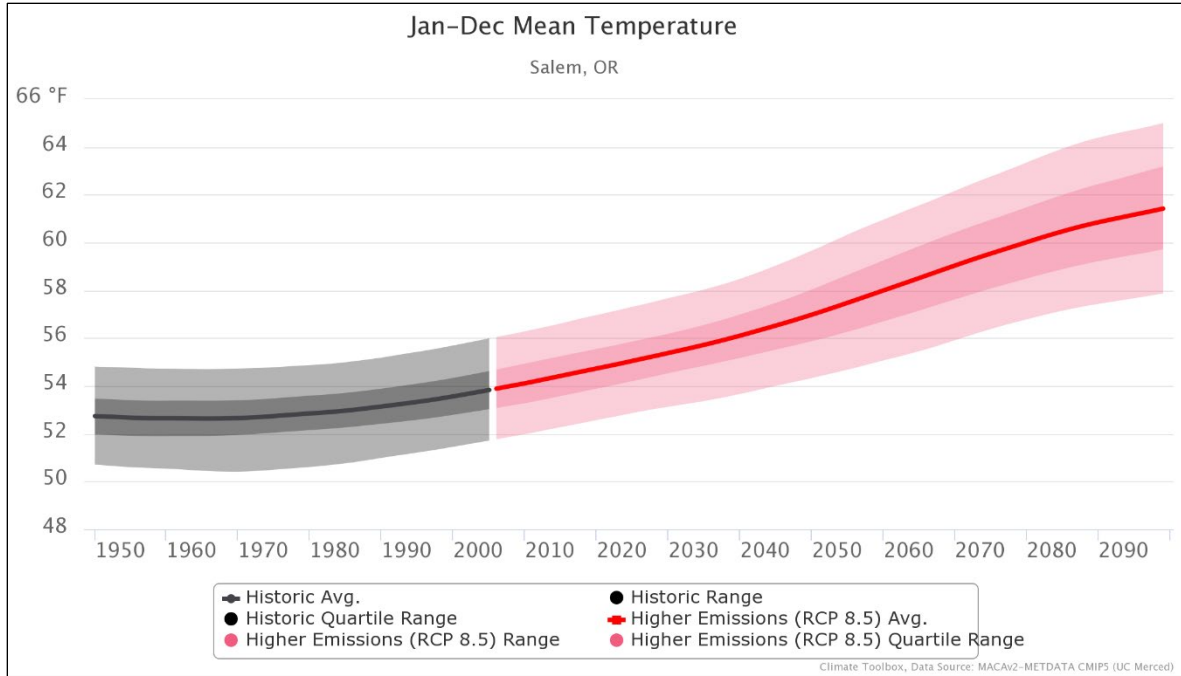
It is expected that the Willamette Valley floor (roughly along the axis of the I-5 corridor) will experience the greatest relative warming. End-of-century mean summer temperatures are projected to be 10.4°F greater than 1971–2000 temperatures (Figure3-13).

The likelihood of higher temperatures in the future may be the greatest concern for the WVS EIS resource areas' qualitative climate change impact determinations. This trend will likely increase future consumptive water demand and could make future water scarcity and drought-like conditions more severe and frequent. Increasing water temperature will likely pose a substantial stressor of concern for the fish and wildlife operations at USACE projects. Although it is difficult to directly project climate-impacted water temperature, ambient air temperature changes can serve as a proxy for future water temperature conditions.

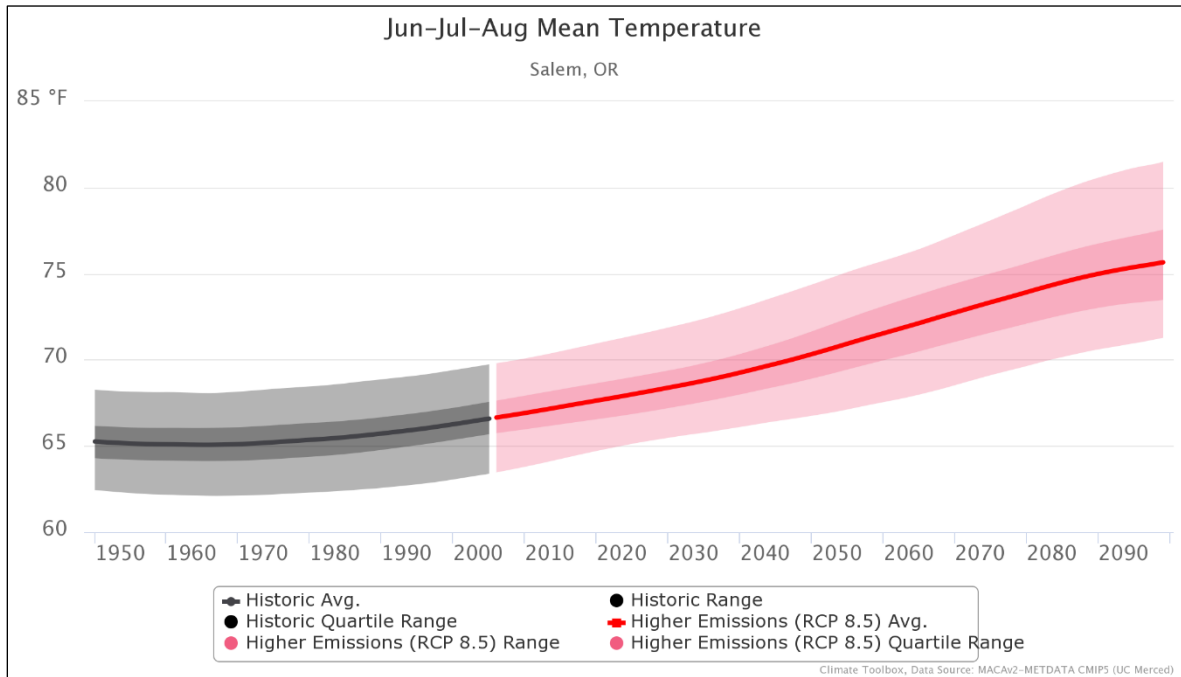
Precipitation in the Middle Willamette River Subbasin is projected to increase in the winter months with some of the most pronounced increases being in the months of December through February (DJF). Figure 3-14 graphically shows expected precipitation change using box plots of winter (DJF) precipitation change. The plots graphically show the historical and three 30-year future epochs. Shown below, winter precipitation is projected to increase by approximately 2.2 inches (from the Climate Toolbox). This change would likely stress USACE flood space and winter flood operations.

Average summer precipitation (already low) is expected to decline by 0.2 inches by the end of the century (Figure 3-15). Lower summer precipitation could stress sustainability of regulated conservation flows and, with increasing air temperatures, increase the need for downstream thermal regulation.

*Willamette Valley System Operations and Maintenance  
Environmental Impact Statement*

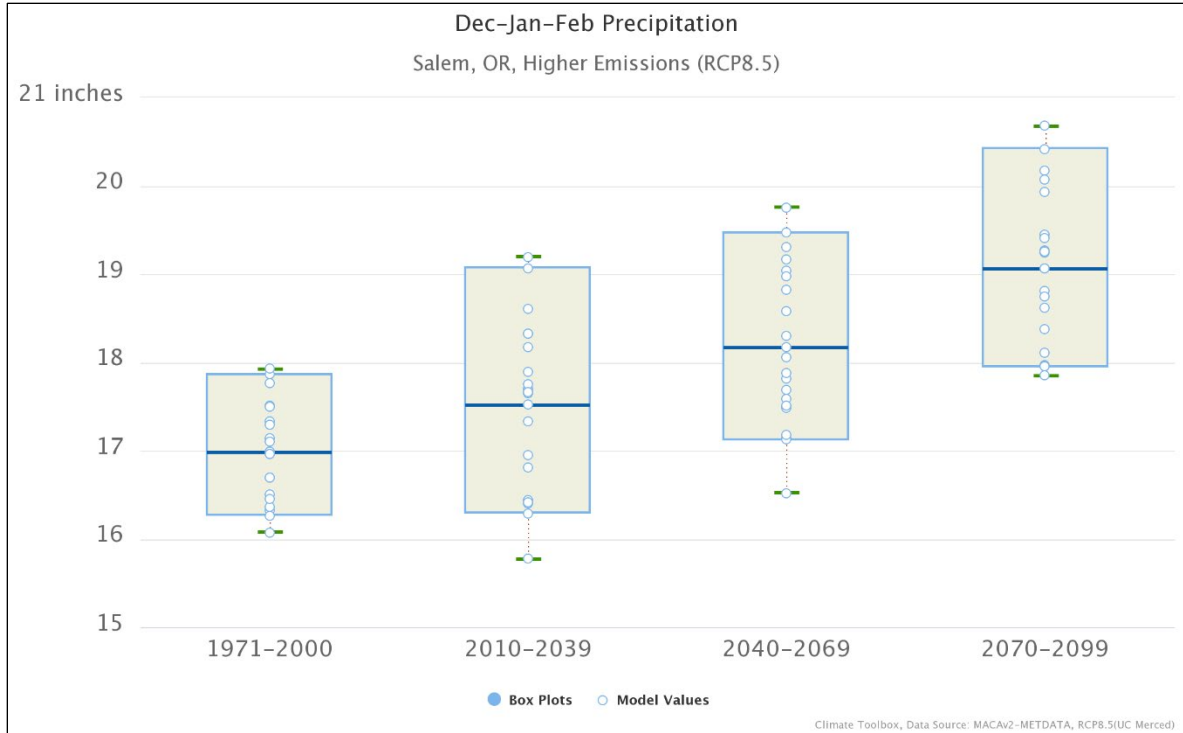


**Figure 3-12. Average Annual Temperature Trends at Salem, Oregon, 1950–2100.**

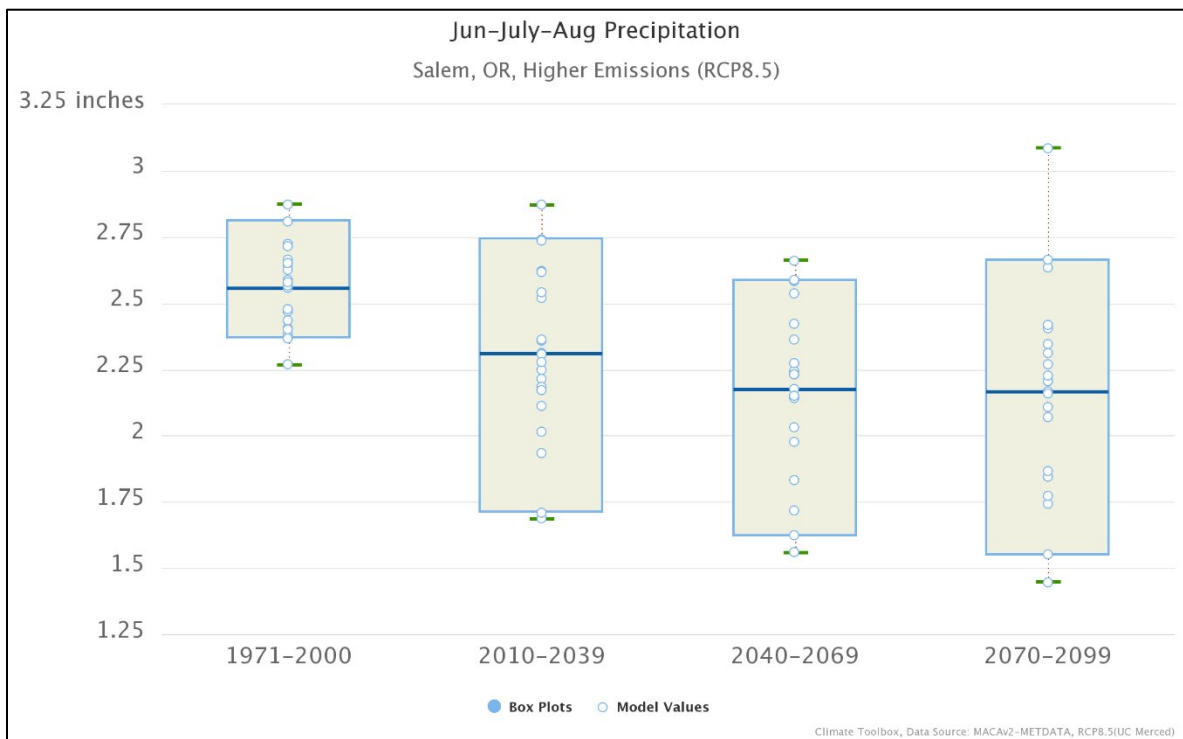


**Figure 3-13. Average Annual Summer Temperature Trends at Salem, Oregon, 1950–2100.**

*Willamette Valley System Operations and Maintenance  
Environmental Impact Statement*



**Figure 3-14. Median Winter Precipitation Trends at Salem, Oregon, 1950–2100.**



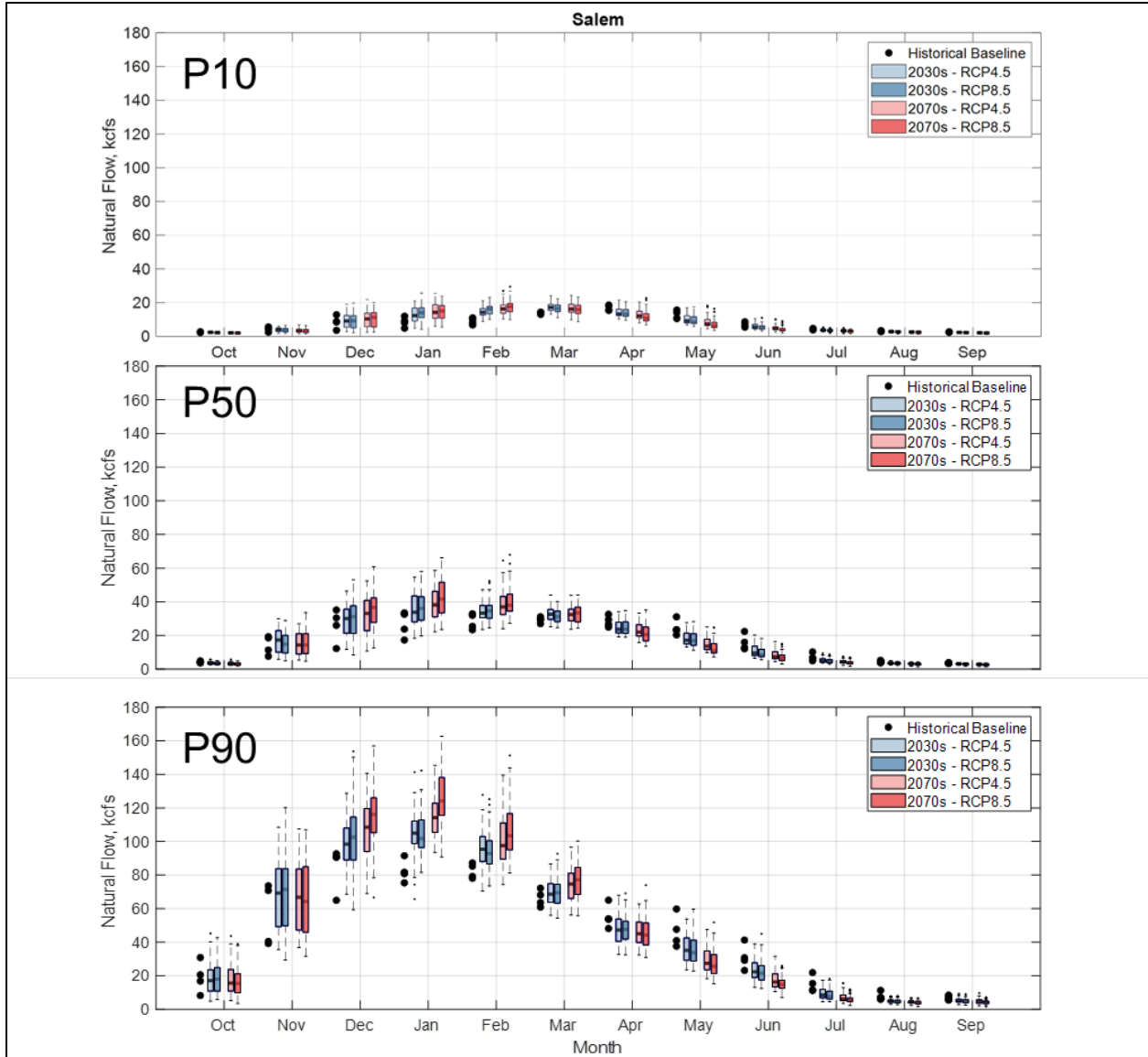
**Figure 3-15. Median Summer Precipitation Trends at Salem, Oregon, 1950–2100.**

*Willamette Valley System Operations and Maintenance  
Environmental Impact Statement*

The warming temperatures and tendency for increased precipitation, particularly in the already wet winter months, result in higher winter volumes. In the summer, there is a tendency for lower flows or a longer period of low flows. The Willamette River Basin area has a tendency toward lower spring and summer flows (RMJOC 2018).

Figure 3-16 (RMJOC 2018) graphically depicts the projected changes in seasonal unregulated (naturalized) streamflow at Salem, representing the prevalent future trends in the Middle Willamette River Subbasin. The summary hydrographs highlight the 10th percentile (more frequent, low flows), 50th percentile (median), and 90th percentile (less frequent, high flows) exceedance. This is graphically summarized for the Willamette River at Salem, OR for the historical period (1975–2005), the 2030s (2020–2049), and the 2070s (2060–2089) (RMJOC 2018). Refer to Figure 3-10 for a legend and explanation of the summary hydrograph presentations.

*Willamette Valley System Operations and Maintenance  
Environmental Impact Statement*



**Figure 3-16. Willamette River at Salem, Oregon Summary Hydrographs.**

Source: RMJOC-II, 2018.

Note that there is minimal spring melt response (freshet) at Salem, OR. This is likely due to the downstream reach attenuation of the spring melt runoff.

Table 3-1 summarizes the percent of normal relative to historical baseline. It exemplifies the relative degree of monthly and seasonal change. Positive flows tend to increase in December through March while shoulder seasons (spring and fall) with summers tend to decrease relative to modeled baseline flows.

*Willamette Valley System Operations and Maintenance  
Environmental Impact Statement*

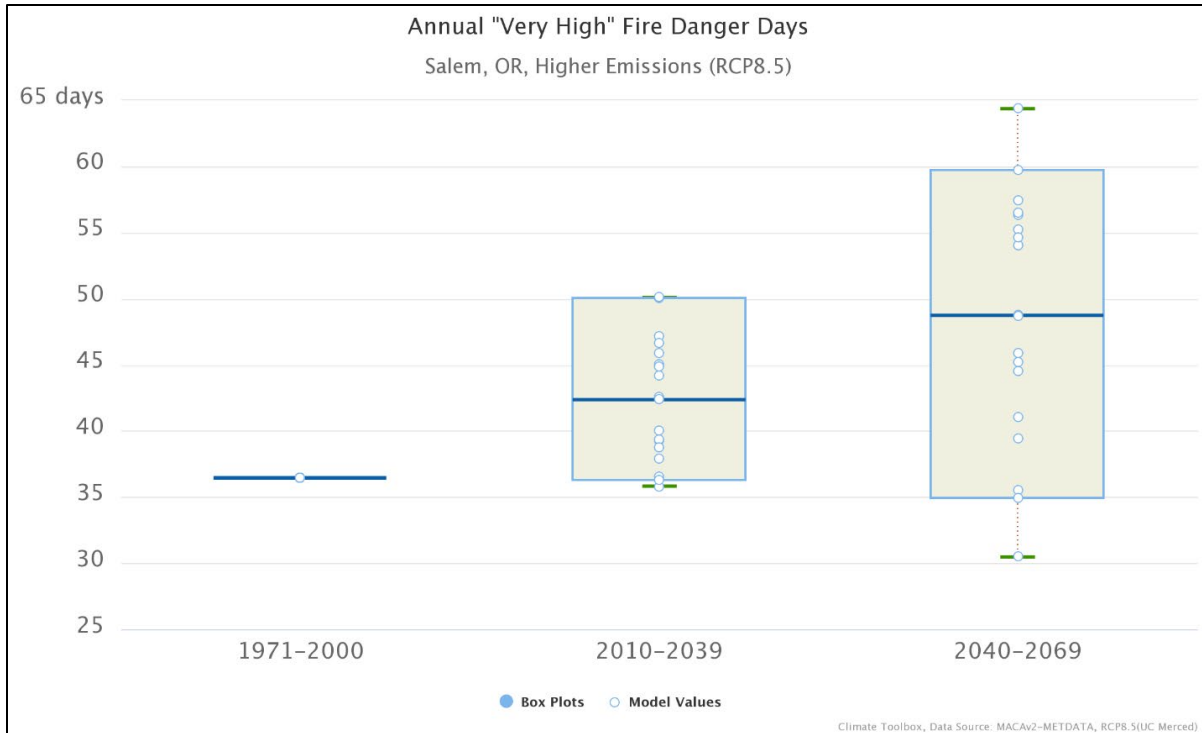
**Table 3-1. Salem Flow Change.**

SLM Median change - RCP 8.5 2030s and 2070s vs Historical baseline (1976-2005)						
Month	10th Percentile kcfs		Median kcfs		90th Percentile kcfs	
	2030s	2070s	2030s	2070s	2030s	2070s
Oct	-0.3	-0.5	-0.2	-0.5	0	-0.5
Nov	0	-1.4	0.1	0.1	12	1
Dec	1	3	6	12	20	37
Jan	6	7	10	13	19.5	40.5
Feb	7	8.5	6	9	9	20
Mar	3	2	2	4	7	15
Apr	-4	-6	-6	-8.5	-15	-16
May	-4.5	-6.5	-7	-14.5	-6	-21
Jun	-2	-3	-8.5	-11	-9.5	-12
Jul	-1	-1.2	-2.5	-3.5	-10	-14
Aug	-0.3	-0.5	-1	-1.5	-4	-5
Sep	-0.1	-0.2	-0.2	-0.6	-4	-5

Higher winter (DJF) inflows and increasing frequency of systemwide winter flood events will likely complicate system flood risk management, especially during winter (e.g., at Salem and Portland, OR) when future flow volumes are likely to increase relative to historical norms.

During the spring, summer, and fall, decreased precipitation and warmer conditions will likely reduce inflows to reservoirs and could stress seasonal refill and conservation operational objectives. Lower inflows for the refill will likely complicate follow-on conservation season operations. For example, minimum flows for fisheries and releases for consumptive uses are dependent on and driven by concurrent refill inflows and demands in the conservation season, respectively.

Increasing fire risk is similarly driven by higher ambient temperatures and low precipitation. Figure 3-17 graphically shows the trend of high fire risk days in the future.



**Figure 3-17. Salem, Oregon Annual Very High Fire Danger Days.**

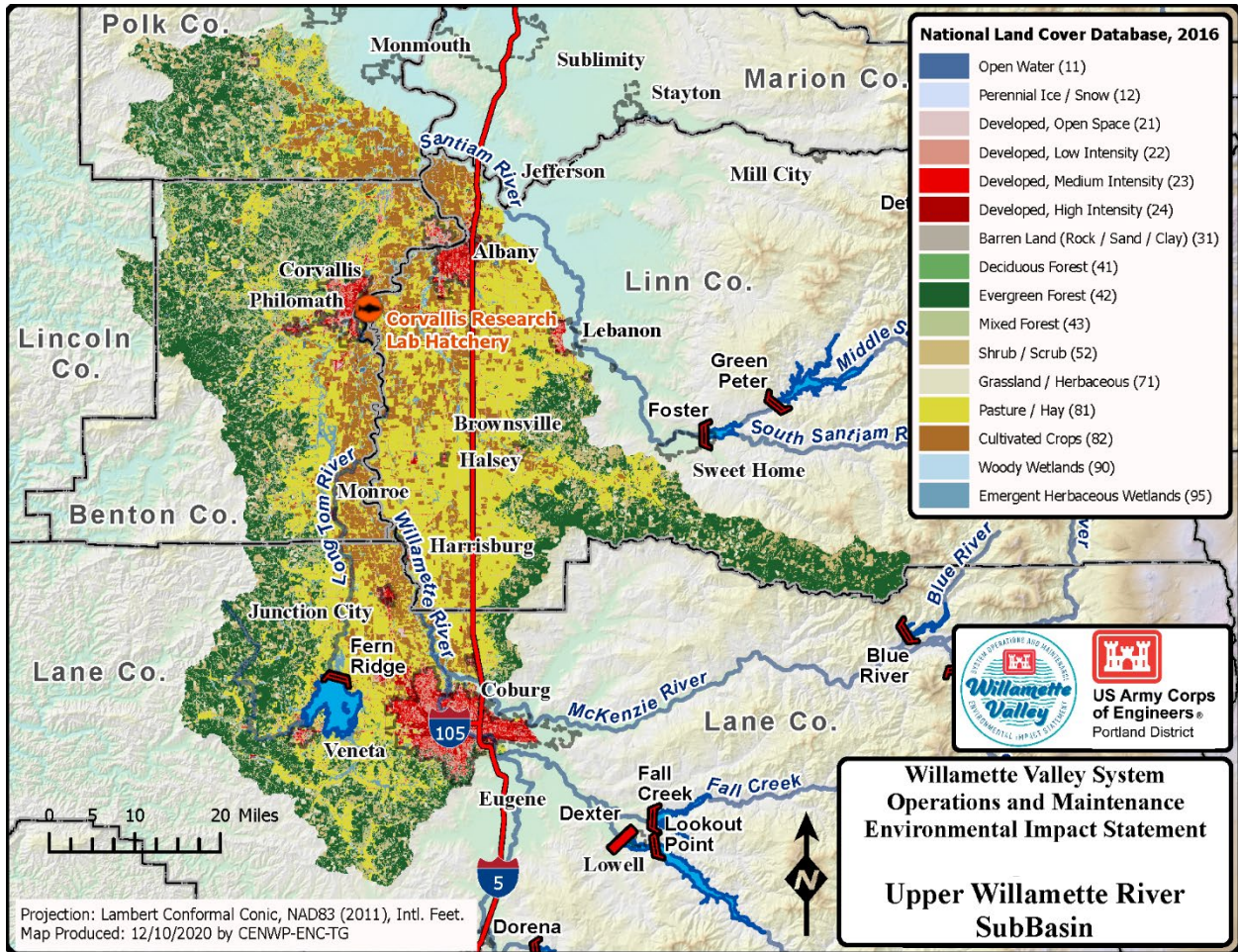
### 3.2.5 Upper Willamette River Subbasin

The Upper Willamette River Subbasin is shown in Figure 3-18. The subbasin straddles the Interstate 5 (I-5) corridor and stretches between two major metropolitan areas: Albany, OR at the north end to the Eugene/Springfield metro area to the south. The principal Corps dam in this subbasin is Fern Ridge on the Long Tom River.

Warming is projected in the Upper Willamette River Subbasin. Figure 3-19 shows that average annual temperatures at Eugene, OR are projected to increase by 8°F compared to the 1971–2000 baseline by the end of the century. End-of-century mean summer temperatures are projected to be +10.3°F warmer, as shown in Figure 3-20. Spring peak runoff from SWE is negligible in the Upper Willamette River Subbasin as elevations are lower. The peak flow from snowmelt is attenuated but the spring volume would likely help keep tributaries and mainstem flows elevated into the summer months.

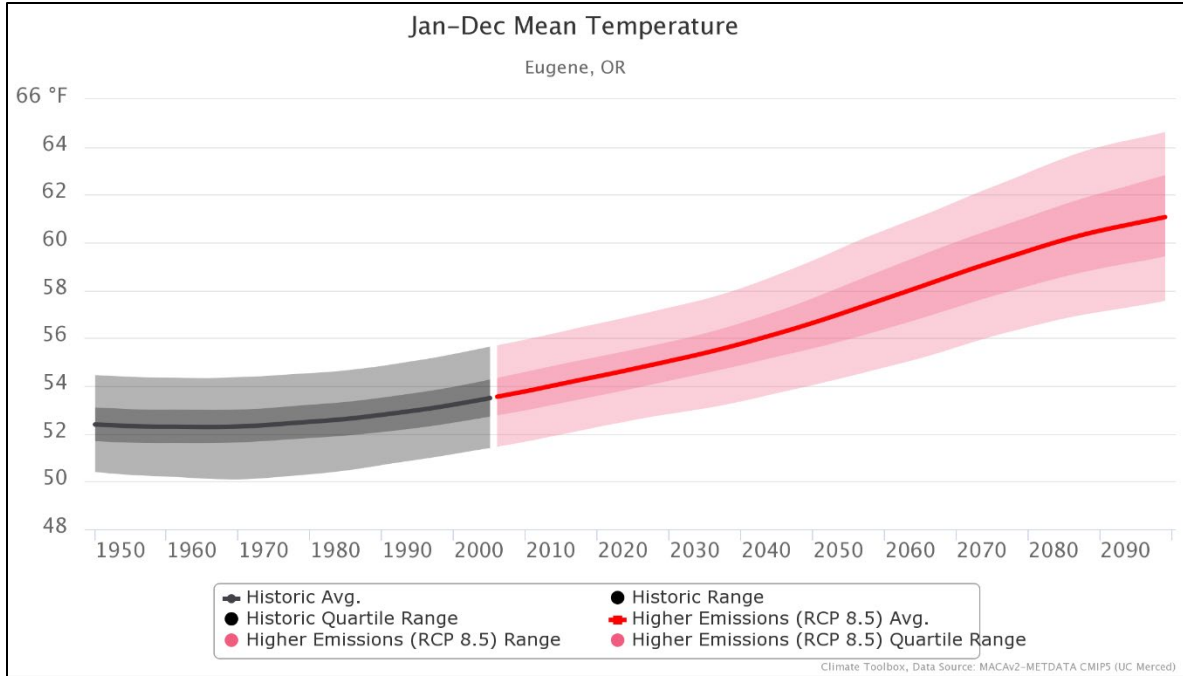
Like the rest of the low-lying Willamette Valley, precipitation in the Upper Willamette River Subbasin is projected to increase in the winter months, December through February. Figure 3-21 graphically shows expected winter precipitation change at Eugene, OR with box plots of winter (DJF) precipitation change for historical and three future 30-year epochs. As shown in Figure 3-21, winter precipitation is projected to increase by approximately 2.2 inches, the same as projected for Salem, OR. Summer precipitation (Figure 3-22) is already very low and will decrease similarly to Salem, OR as shown.

*Willamette Valley System Operations and Maintenance  
Environmental Impact Statement*

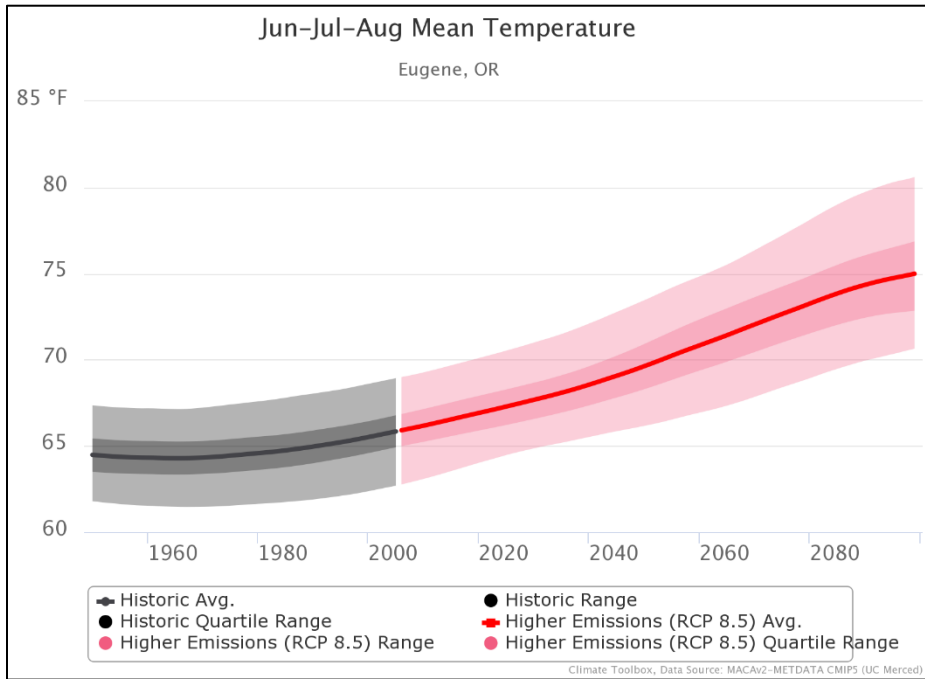


**Figure 3-18. Upper Willamette River Subbasin.**

*Willamette Valley System Operations and Maintenance  
Environmental Impact Statement*

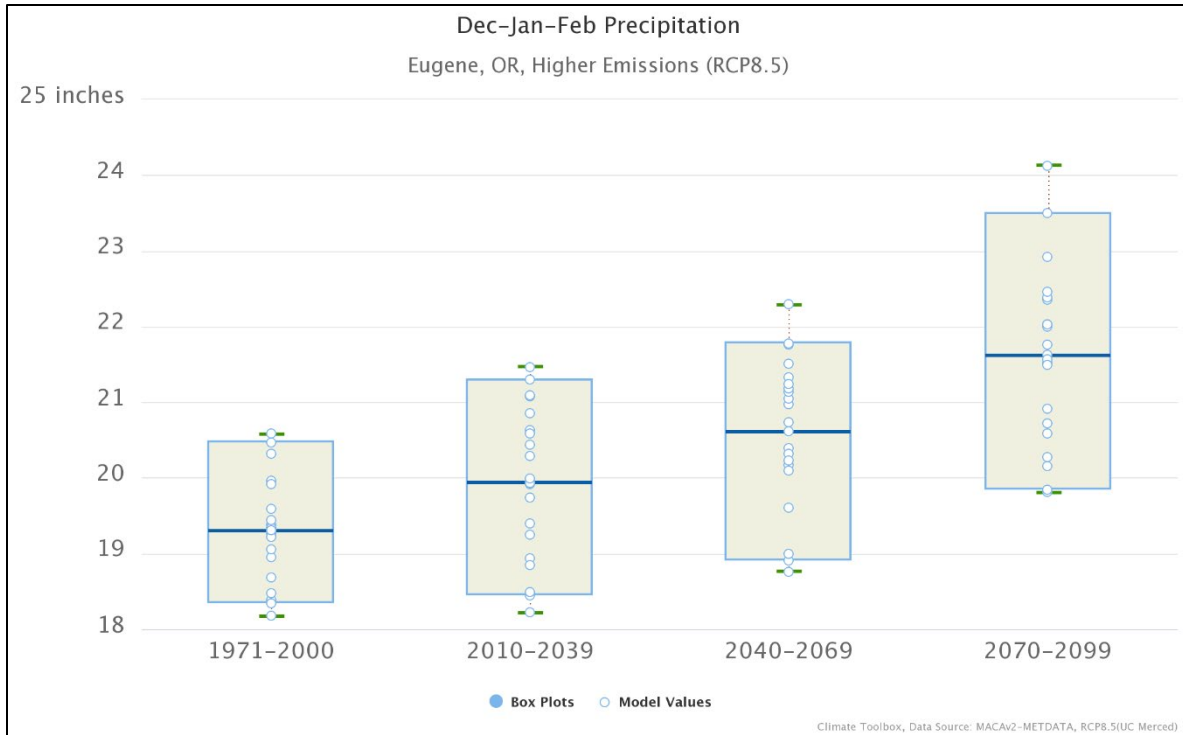


**Figure 3-19. Average Annual Temperature Trends at Eugene, Oregon, 1950–2100.**

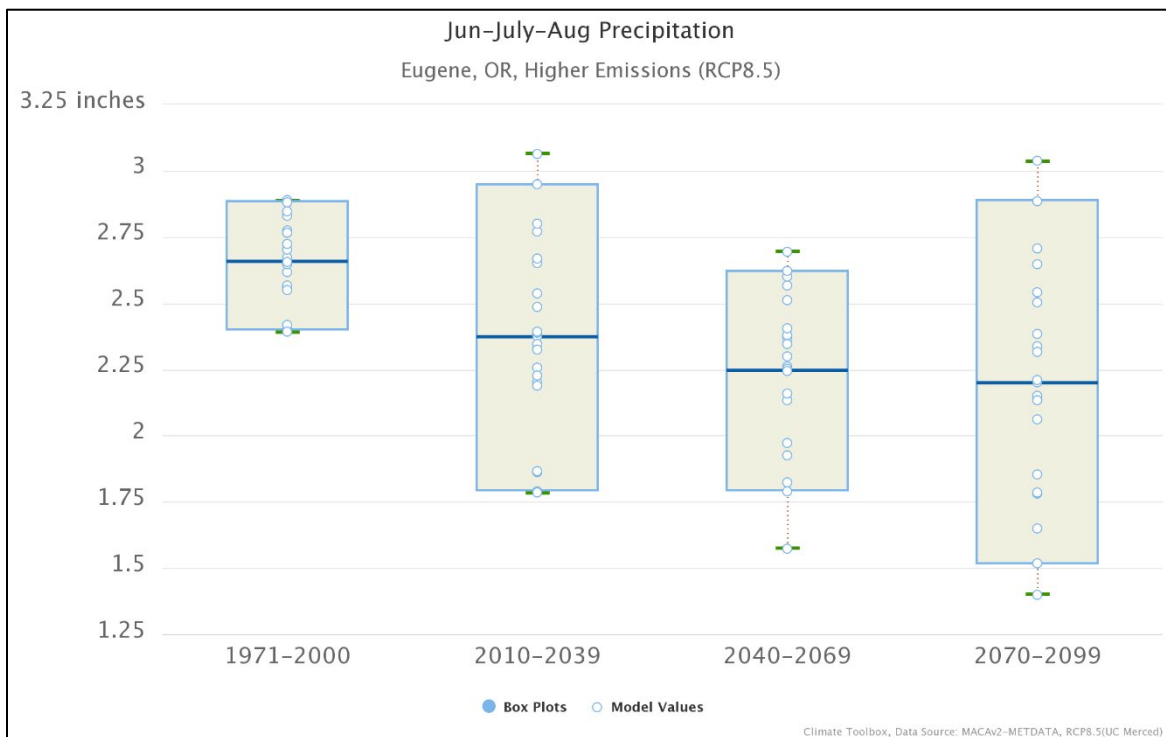


**Figure 3-20. Average Annual Summer Temperature Trends at Eugene, Oregon, 1950–2100.**

*Willamette Valley System Operations and Maintenance  
Environmental Impact Statement*



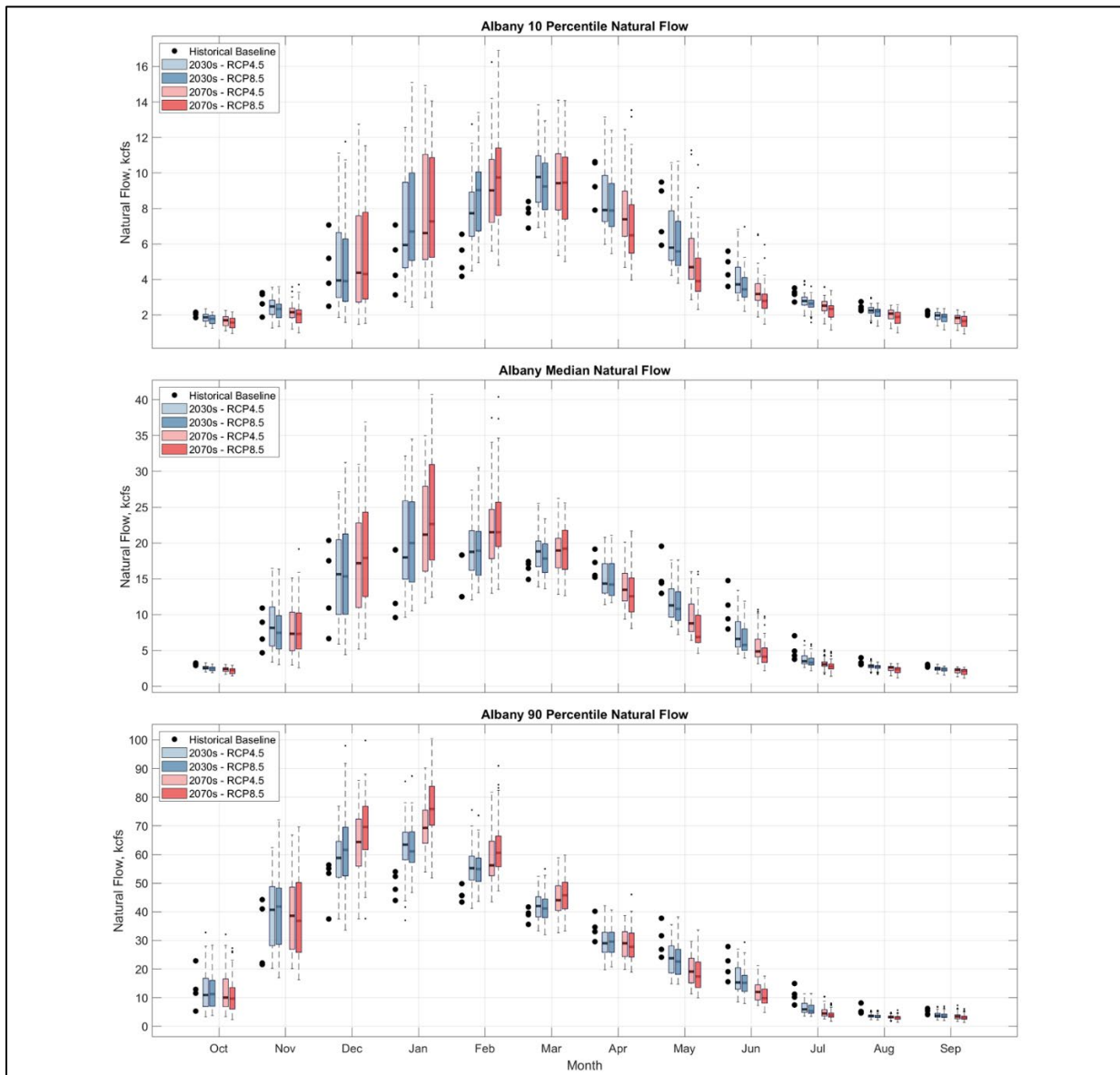
**Figure 3-21. Median Winter Precipitation Trends at Eugene, Oregon, 1950–2100.**



**Figure 3-22. Median Summer Precipitation Trends at Eugene, Oregon, 1950–2100.**

*Willamette Valley System Operations and Maintenance  
Environmental Impact Statement*

Warming temperatures and overall increased precipitation, especially in the winter, will result in higher winter volumes in the Willamette River. In the summer, there is a tendency for lower flows or a longer period of low flows. The Willamette River Basin area has a tendency toward lower spring and summer flows (RMJOC 2018). The natural (unregulated) streamflow trends for the Upper Willamette River Subbasin, as reported at Albany, are shown in Figure 3-23. Figure 3-23 reflects the same overall trends as the exceedance plots at Salem, OR, shown in the previous section.



**Figure 3-23. Willamette River at Albany, Oregon Summary Hydrographs.**

Source: RMJOC-II, 2018

Table 3-2 summarizes the percent change in the median future relative to historical baseline flow. It exemplifies the relative degree of monthly and seasonal change. Positive flows tend to

*Willamette Valley System Operations and Maintenance  
Environmental Impact Statement*

increase in November, December, and March while flows in spring through fall seasons tend to decrease relative to modeled baseline flows.

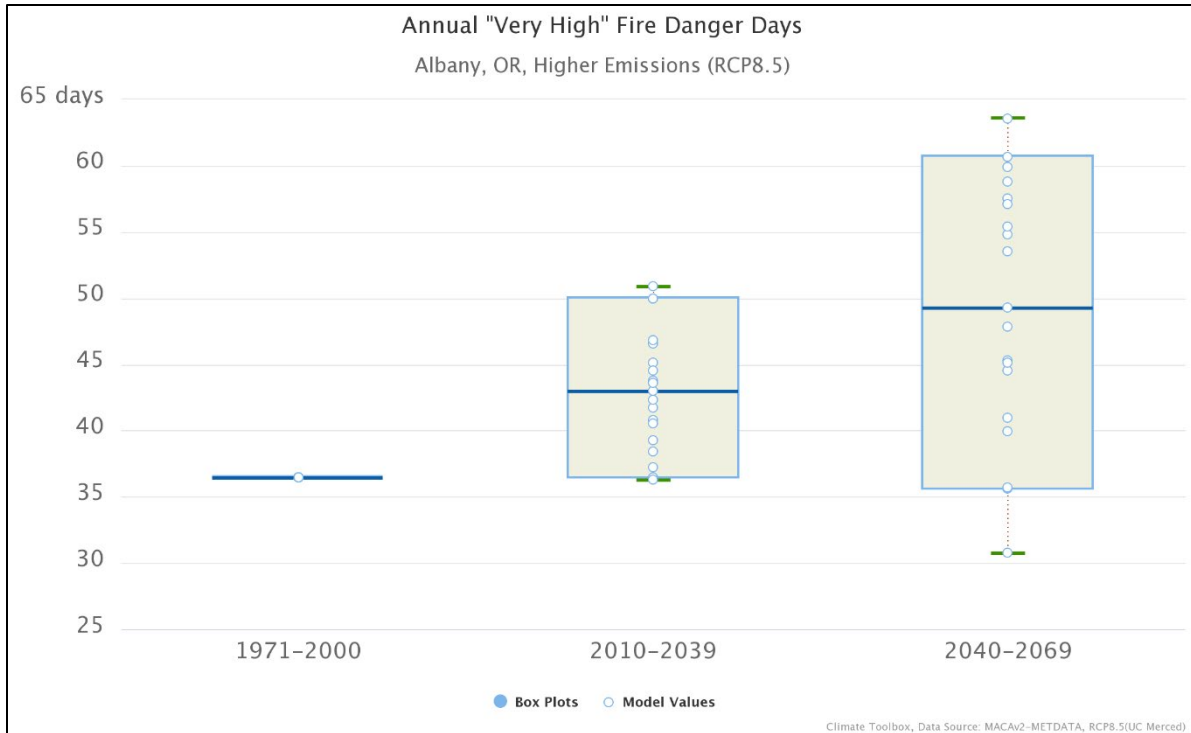
**Table 3-2. Albany Flow Change.**

ALB Median change - RCP 8.5 2030s and 2070s vs Historical baseline (1976-2005)						
Month	10th Percentile kcfs		Median kcfs		90th Percentile kcfs	
	2030s	2070s	2030s	2070s	2030s	2070s
Oct	-0.1	-0.2	-0.8	-1	-1.5	-2
Nov	-0.1	-0.2	-0.1	-0.1	6	3
Dec	-0.3	-0.1	0.6	3.3	9	17.8
Jan	1.8	2.3	5	2.5	12	27
Feb	3.8	4.4	3.4	6.9	7	12.5
Mar	1.3	1.5	1.8	3	2	6.5
Apr	-1.4	-3.1	-3	-4.5	-4.5	-5
May	-2.1	-3.9	-4	-8	-8	-11
Jun	-0.4	-1.5	-5.5	-7	-3	-10
Jul	-0.9	-1	-1.2	-2.5	-5.5	-7.5
Aug	-0.2	-0.4	-1.3	-1.7	-3.5	-3.7
Sep	-0.2	-0.25	-0.1	-0.5	-0.5	-0.7

Climate change effects in the Upper Willamette River Subbasin are very similar to the Middle Willamette River Subbasin. Higher winter (DJF) inflows and increasing frequency of systemwide winter flood events will likely complicate system and local flood risk management. During winter, increased project inflow and back-to-back high-water events could lead to increased severity of flooding. Back-to-back flood events tax available flood space, and projects may not completely empty with short periods between events. With projected higher precipitation in the winter, the likelihood of back-to-back events is likely to increase.

High-water events that occur during refill may not be stored for use later in the conservation season and thus not available for use as summer minimum flow releases and thermal regulation operations (10 May through 15 November). The Willamette River April 2019 high-water event (USACE 2019) was a flood that occurred as reservoirs were refilling. Higher pools at the time of the event complicated the flood reduction operations, and subsequent emptying of the pools post event was by water management regulators (USACE 2019). Occurrence of late high-water events could become more common in the future and emphasize the importance of highly flexible flood season regulation. Measures with more operational flexibility (e.g., latitude of decision making) and availability in a broader range of release and storage options would be more resilient to projected climate change trends.

Overall, decreased precipitation and warmer conditions could reduce inflows to reservoirs and reduce normal baseflows in tributaries and downstream mainstream reaches. Lower inflows during refill will likely complicate follow-on conservation season low-flow fish operations, recreation, and other conservation objectives. Warming downstream flows during the summer and fall months will likely impact how temperature operations are performed. An additional climate change stressor variable of concern is the projection of increased likelihood of higher fire risk days. Figure 3-24 graphically shows the trend of high fire risk days in the future.



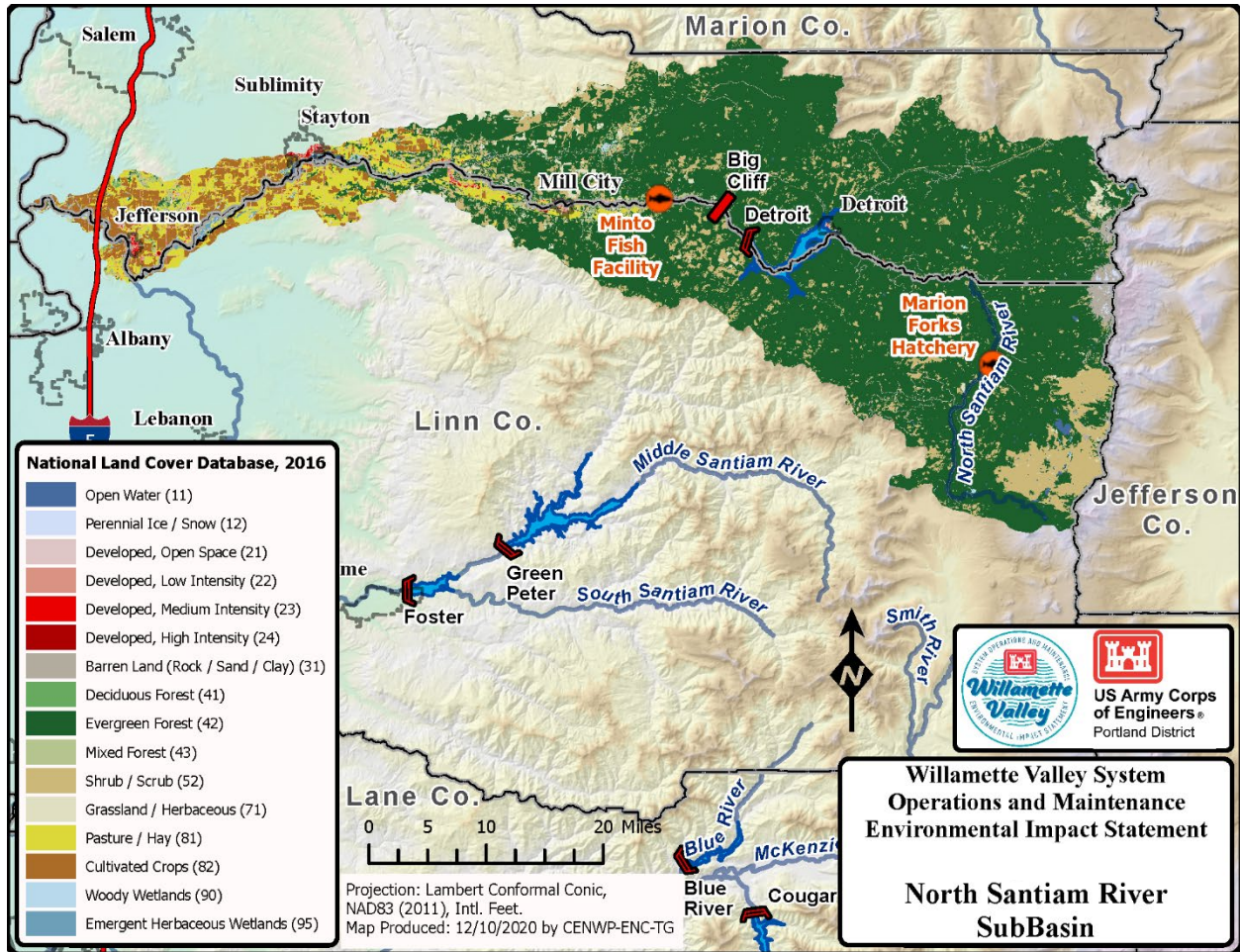
**Figure 3-24. Albany, Oregon Annual Very High Fire Danger Days.**

### 3.2.6 North Santiam River Subbasin

Figure 3-25 graphically shows the North Santiam River Subbasin. The North Santiam River Subbasin is approximately 766 square miles. The North Santiam fork combines with the mainstem Santiam River at Jefferson, OR. The subbasin is defined by steep and mountainous terrain until Gates, OR where the slopes become gentler and the river bottom lands expand to the valley floor. Toward the lower end of the subbasin at Stayton, OR there is extensive agriculture and residential properties. The North Santiam River Subbasin average elevation is 2,900 feet while the high elevation is 10,457 feet on Mount Jefferson. The low spot in the subbasin is approximately elevation 160 feet (NAVD88).

The North Santiam River headwater project is Detroit Dam. It is multipurpose in nature and is operated for power generation (100 MW), flood risk reduction, and water conservation. Big Cliff Dam is located about 3 miles downstream of Detroit Dam. It acts as a re-regulation ("rereg") project and serves to attenuate and mitigate power peaking flows from Detroit Dam. Big Cliff Dam also has power generation capacity at 18 MW from one turbine. ESA-listed species are present in the subbasin as well. There is a fish hatchery at Marion Forks on the North Santiam River above Detroit. ESA-listed species in the North Santiam River Subbasin include winter steelhead and spring Chinook salmon.

*Willamette Valley System Operations and Maintenance  
Environmental Impact Statement*

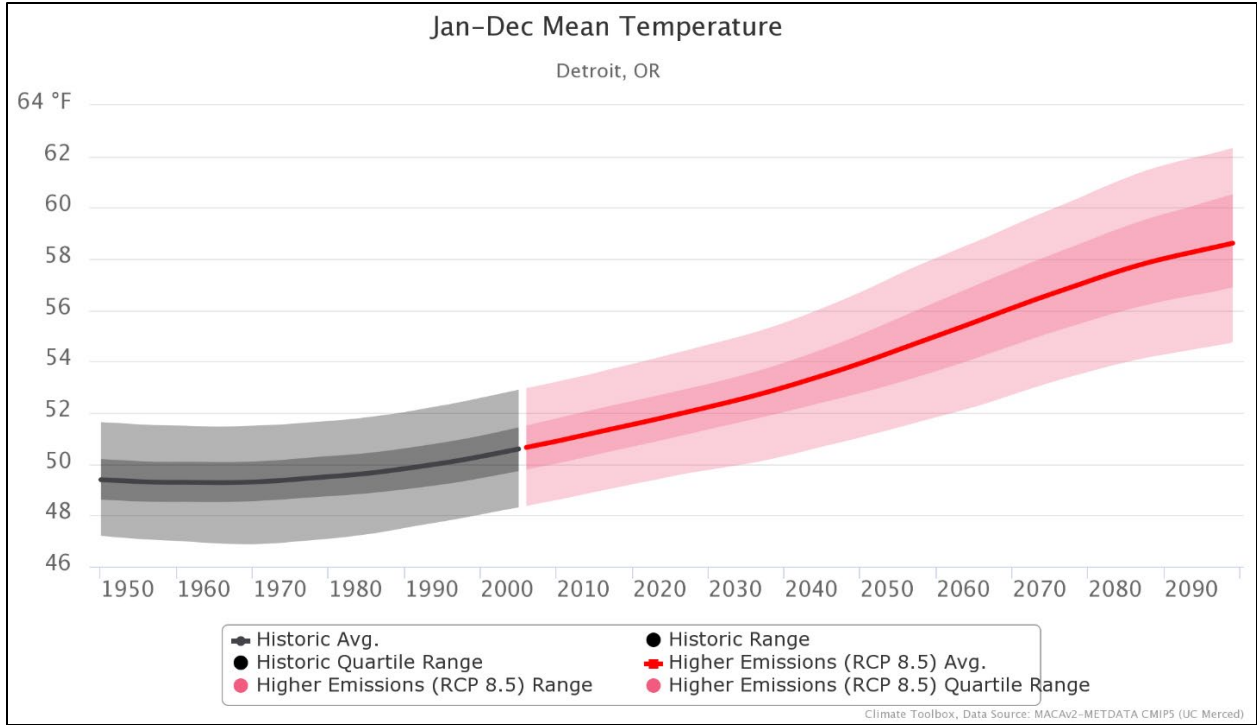


**Figure 3-25. North Santiam River Subbasin.**

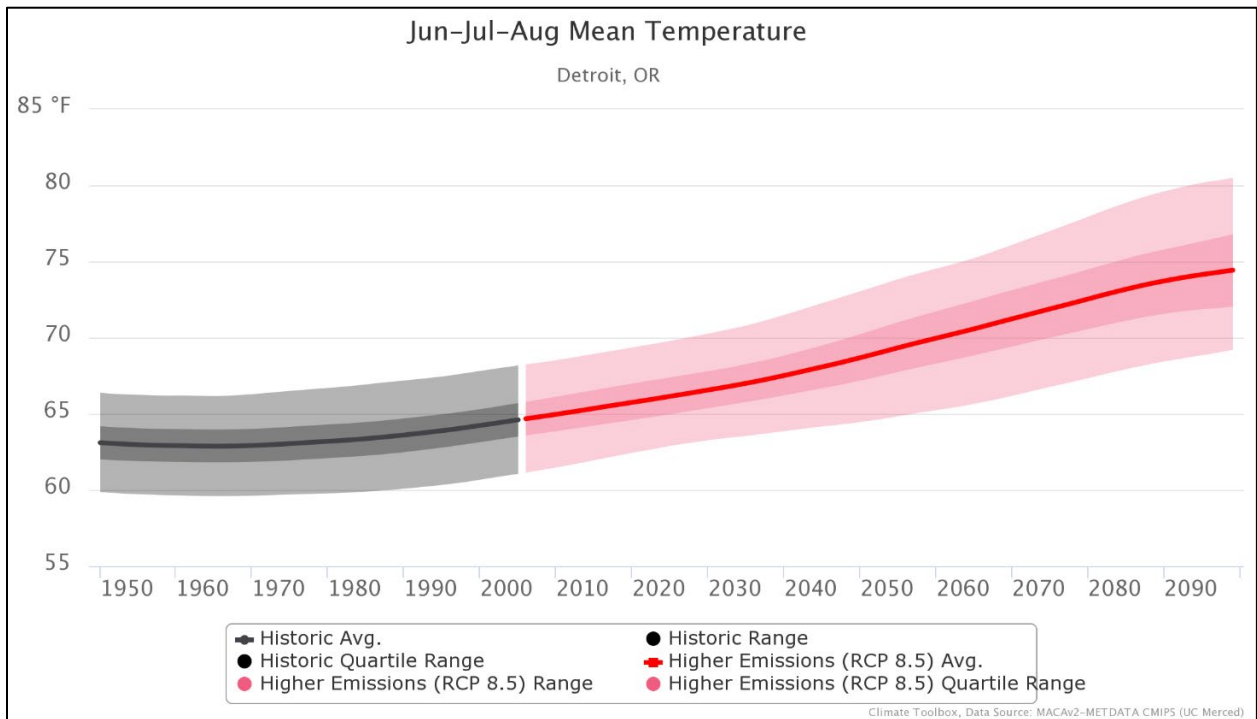
The topography in the majority of the North Santiam River Subbasin is generally mountainous and the primary land cover is upland forest. Snowpack is also often present during the winter in the higher elevations. Santiam River Subbasin snowpack melt historically produces a substantial proportion of spring freshet volume at Salem, OR.

Future (ambient) temperature projections in the subbasin have potential implications for the large water temperature downstream control tower as well as the fish collection project proposed at Detroit Dam. The temperatures at Detroit Dam are projected to increase as shown in Figure 3-26 (annual change) and Figure 3-27 depicting summer projections at the site.

*Willamette Valley System Operations and Maintenance  
Environmental Impact Statement*

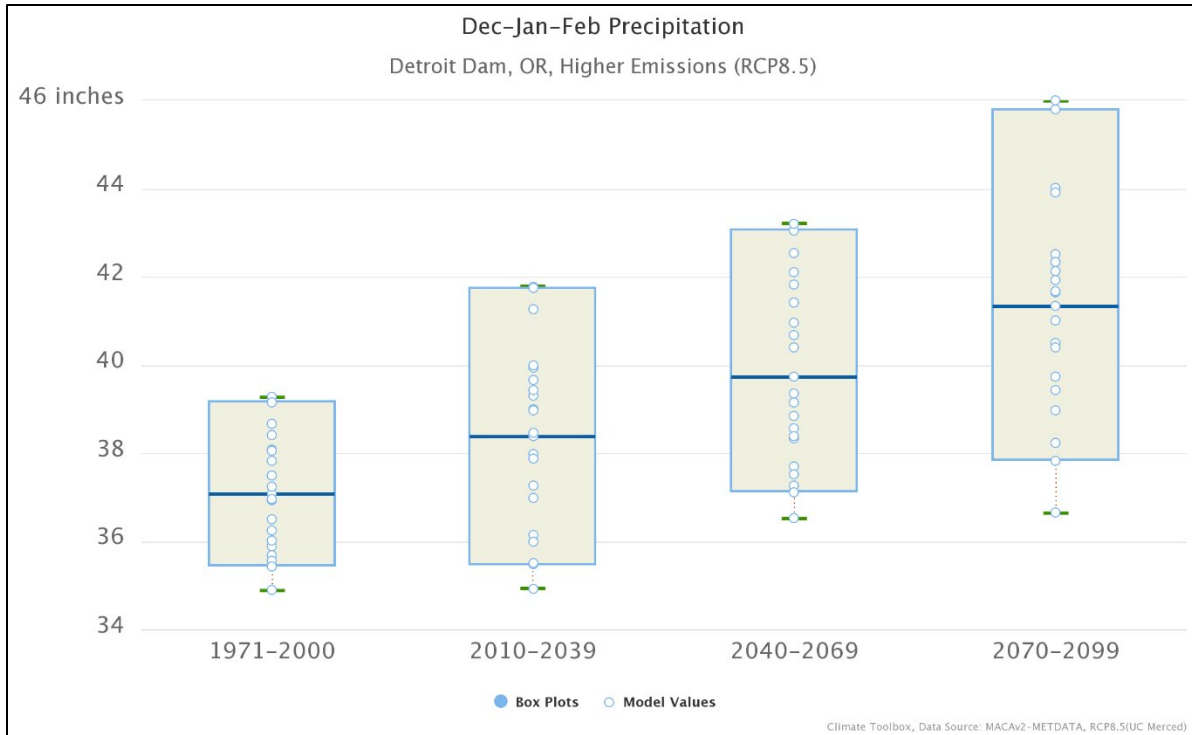


**Figure 3-26. Average Annual Temperature Trends at Detroit, Oregon, 1950–2100.**

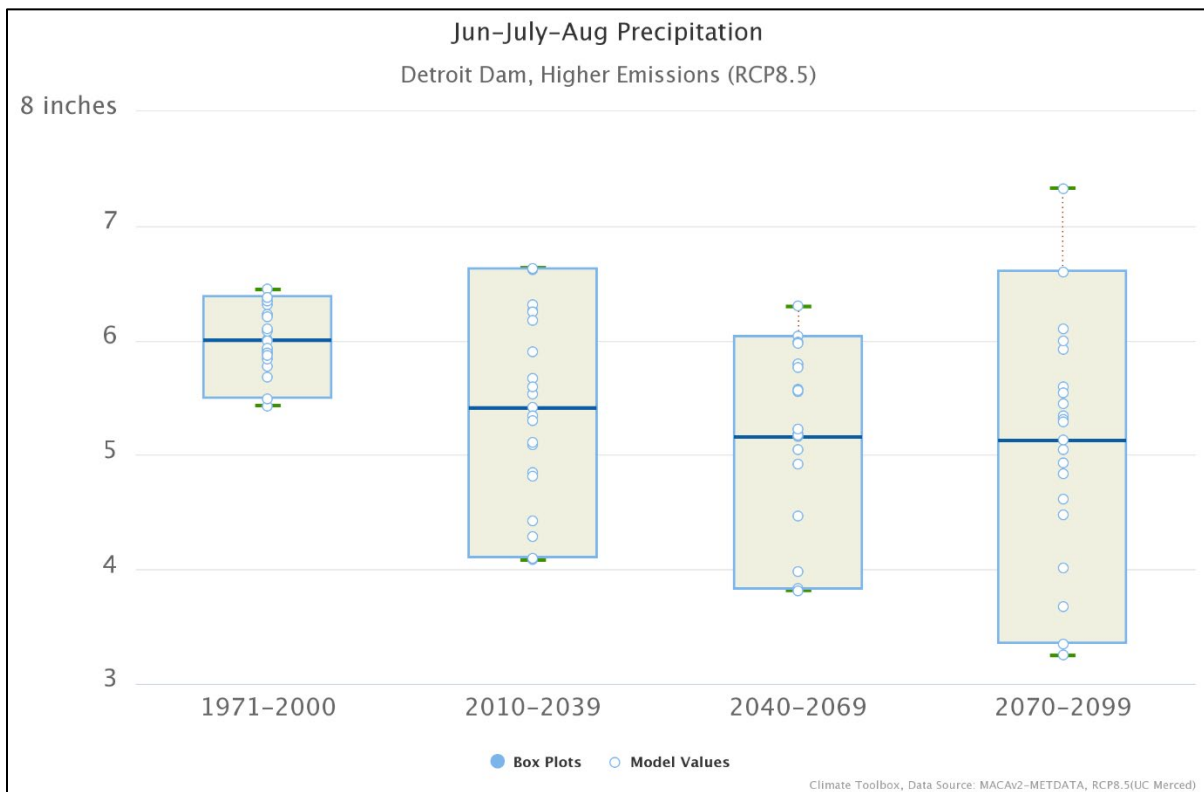


**Figure 3-27. Average Annual Summer Temperature Trends at Detroit, Oregon, 1950–2100.**

*Willamette Valley System Operations and Maintenance  
Environmental Impact Statement*



**Figure 3-28. Median Winter Precipitation Trends at Detroit, Oregon, 1950–2100.**



**Figure 3-29. Median Summer Precipitation Trends at Detroit, Oregon, 1950–2100.**

*Willamette Valley System Operations and Maintenance  
Environmental Impact Statement*

Future change of projected air and water temperatures are relevant climate change factors for the EIS. The impacts of warmer temperatures are most consequential for aquatic species. However, overall ecosystem function and habitat health are also very sensitive to projected air temperature and water temperature increases. Figure 3-26 through Figure 3-29 summarize projections indicating increasing temperature trends are likely through the end of the century. For the North Santiam River Subbasin, the relative change is projected to be somewhat greater than in the Middle and Upper Willamette River Subbasins. Figure 3-26 indicates that average annual temperatures at Detroit, OR are projected to increase by about 9.5°F compared to the 1971–2000 baseline years by the end of the century. End-of-century temperature means for the critical summer season (JJA) are projected to rise +11.5°F as shown in Figure 3-27.

The projected precipitation changes at Detroit Dam are shown to trend upward in the winter and decline in the summer. It is likely that the upper subbasin will experience a future decrease in SWE and become more rain dominated. Streamflow projections mirror the future precipitation trends. SWE, already declining, is likely to become extremely marginal to non-existent by the end of the century (RMJOC 2020). The Detroit Dam unregulated summary hydrographs highlighting the 10th (more frequent, low flows), 50th (median), and 90th (less frequent, high flows) exceedance percentiles are shown in Figure 3-30. Hydrographs at Big Cliff Dam, a re-regulating dam, would follow a similar trend to Detroit Dam. Table 3-2 summarizes the percentile flow changes in terms of relative flow change.

Willamette Valley System Operations and Maintenance  
Environmental Impact Statement

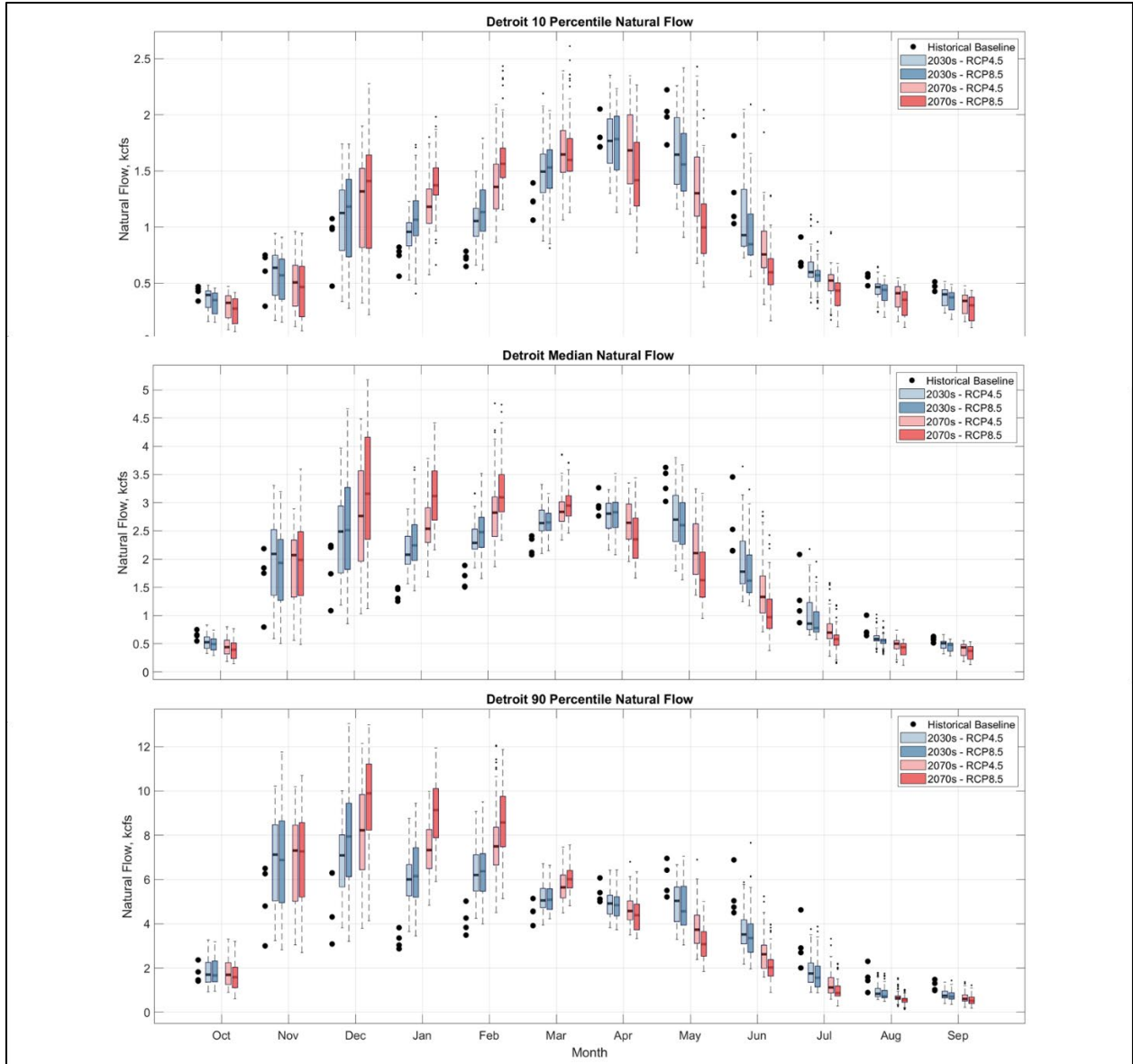


Figure 3-30. North Santiam River at Detroit Dam, Oregon Summary Hydrographs.

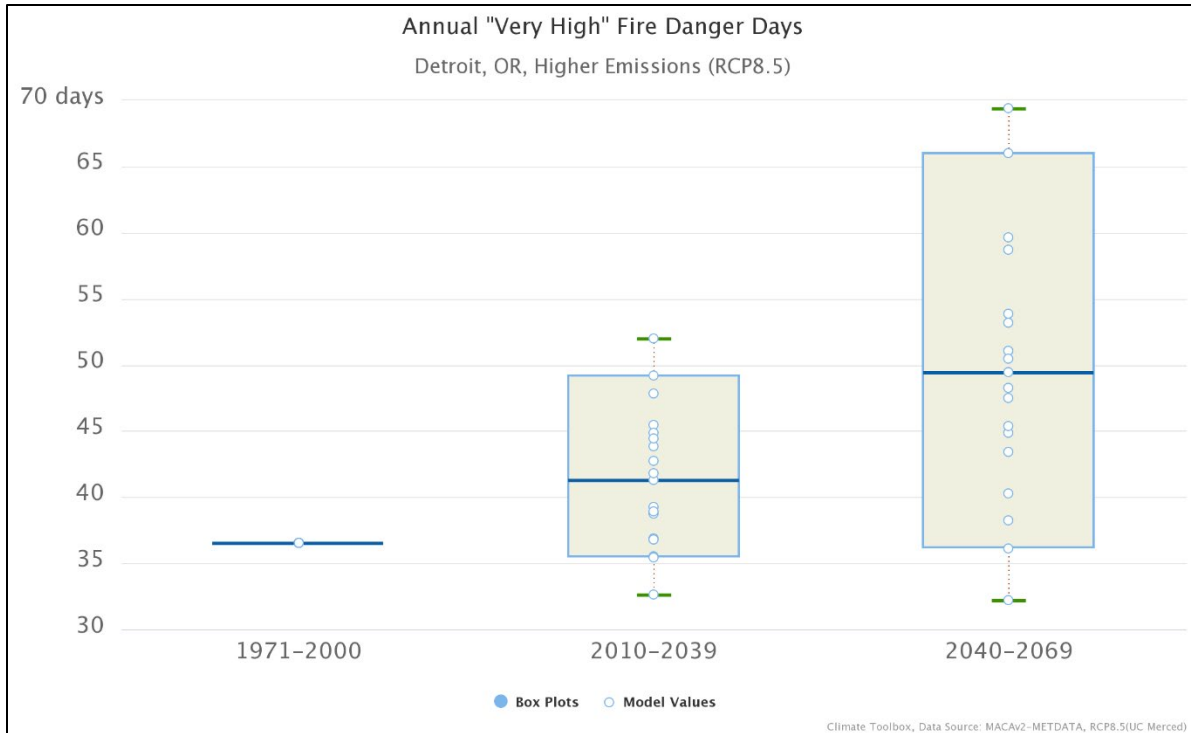
*Willamette Valley System Operations and Maintenance  
Environmental Impact Statement*

**Table 3-3. Detroit Dam Flow Change.**

DET Median change - RCP 8.5 2030s and 2070s vs Historical baseline (1976-2005)						
Month	10th Percentile kcfs		Median kcfs		90th Percentile kcfs	
	2030s	2070s	2030s	2070s	2030s	2070s
Oct	0.15	-0.2	-0.1	-0.12	0.05	-0.1
Nov	0	-0.02	0.3	0.4	1.9	2.2
Dec	0.4	0.65	0.7	1.4	3	4.9
Jan	0.35	0.65	0.85	1.75	2.6	5.7
Feb	0.45	0.8	0.75	1.35	2.2	4.5
Mar	0.3	0.35	0.35	0.65	0.7	1.7
Apr	0	-0.35	-0.1	-0.5	-0.7	-2.4
May	-0.2	-0.8	-0.85	-1.8	-1.7	-3
Jun	-0.45	-0.65	-0.95	-1.5	-2.4	-3.8
Jul	-0.15	-0.3	-0.5	-0.69	-0.95	-1.9
Aug	-0.02	-0.03	-0.25	-0.31	-0.9	-1.4
Sep	-0.02	-0.19	-0.05	-0.15	-0.1	-0.6

The increase in winter flows is indicated by the November through March relative increases in median flows. This is in contrast with the pattern seen in the valley floor, characterized as a single annual (winter) peak and no spring pulse in May. Detroit Dam, OR summary hydrographs portray the different streamflow patterns of a snowpack-affected basin. The historical pattern is for an annual peak in the winter (DJF) followed by a lesser annual rise from the snow melt pulse peaking in May.

The future pattern will reflect higher winter volume and a diminished (or eliminated) spring runoff. This change in timing and quantity will complicate traditional hydro-regulation practices in the Willamette Valley. Operational approaches should consider potential effects from these projected changes to effectively navigate likely changes in the future.



**Figure 3-31. Detroit, Oregon Annual Very High Fire Danger Days.**

As shown in Figure 3-31, the area surrounding Detroit Dam is likely to experience higher fire risk in the future. Median change is upward for both future epochs. The variability of the fire risk days (between GCM models) is greater in the upland basins, in contrast to the valley floor sites, such as Salem and Albany. Detroit, OR suffered heavily from the 2020 fires.

### 3.2.7 South Santiam River Subbasin

The South Santiam River drainage area is approximately 1,040 square miles and is about a third larger than the North Santiam Subbasin (740 square miles). The majority (about 2/3) of the basin is steep and mountainous. The South Santiam River Subbasin average elevation is comparable to the North Santiam River Subbasin, being approximately 2,000 feet (NAVD88). The South Santiam River Subbasin high point is about 5,800 feet (NAVD88) while the low elevation is approximately 215 feet (NAVD88). Green Peter Dam and reservoir straddles the Middle Santiam River. Foster Dam, located about 7 miles downstream, moderates Green Peter Dam power peak releases.

Willamette Valley System Operations and Maintenance  
Environmental Impact Statement

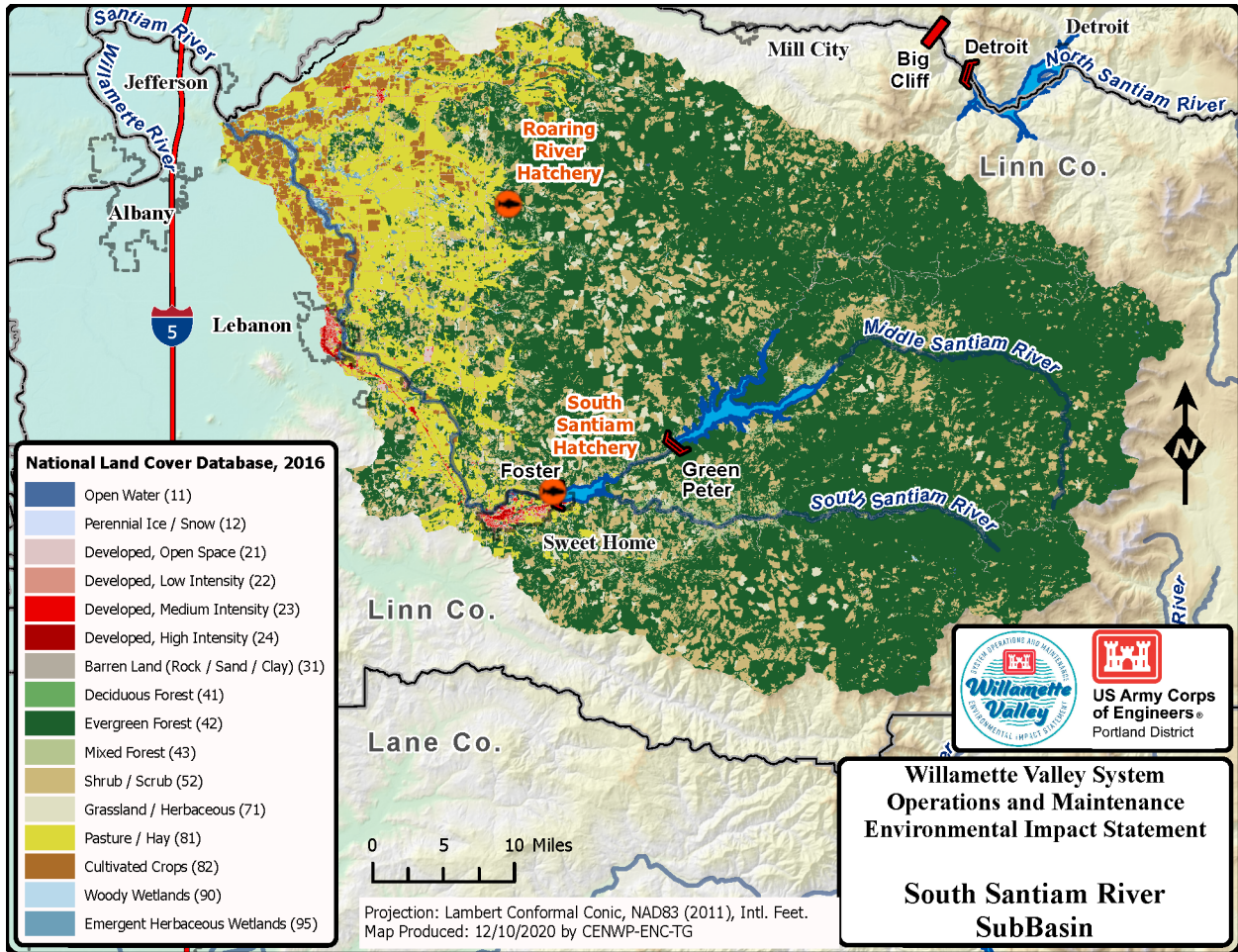
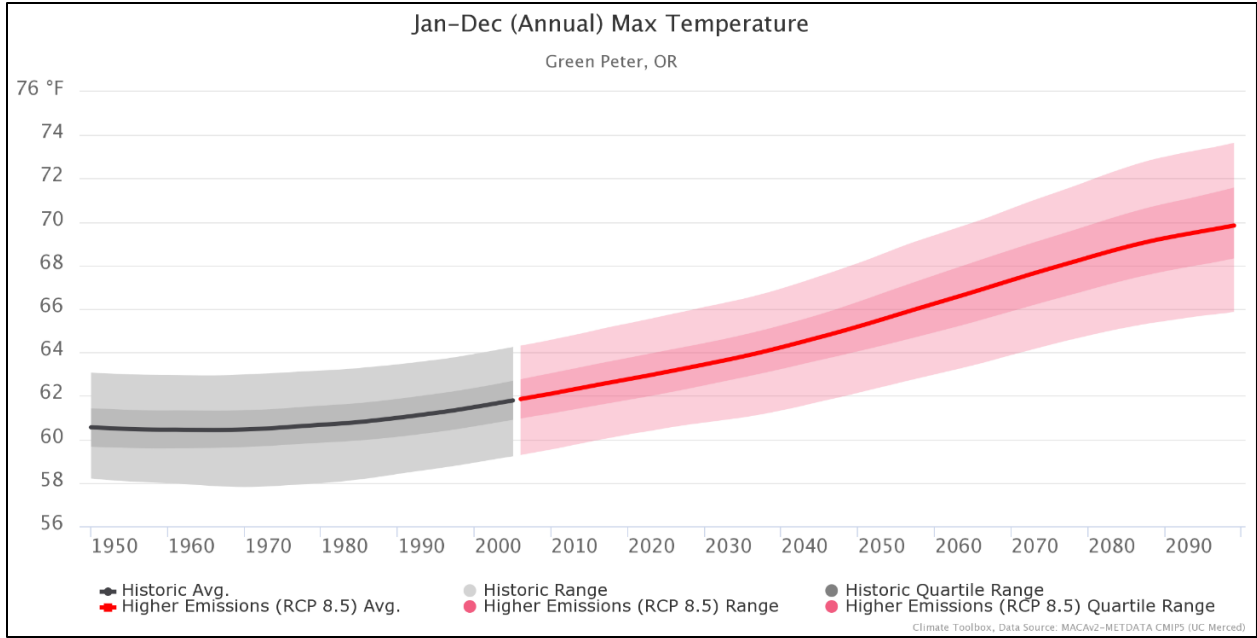


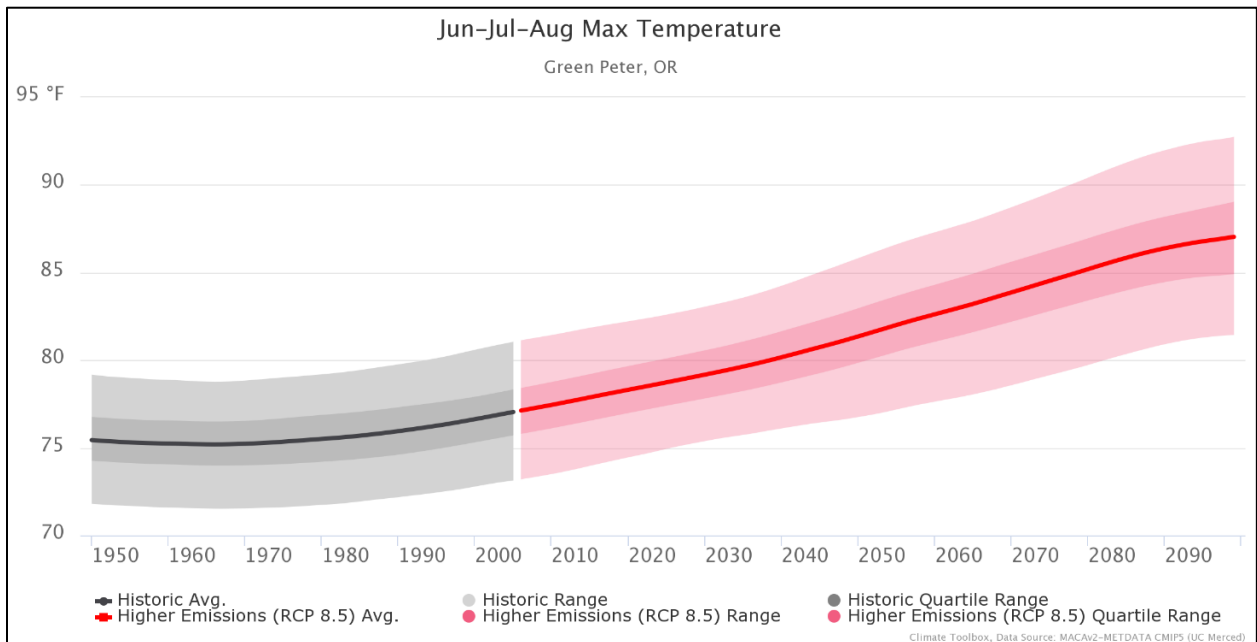
Figure 3-32. South Santiam River Subbasin.

Similar to the North Santiam River Subbasin, temperatures in the South Santiam River Subbasin are projected to increase as shown in Figure 3-33 (annual change) and Figure 3-34 (summertime (JJA) averaged projections at the site).

*Willamette Valley System Operations and Maintenance  
Environmental Impact Statement*

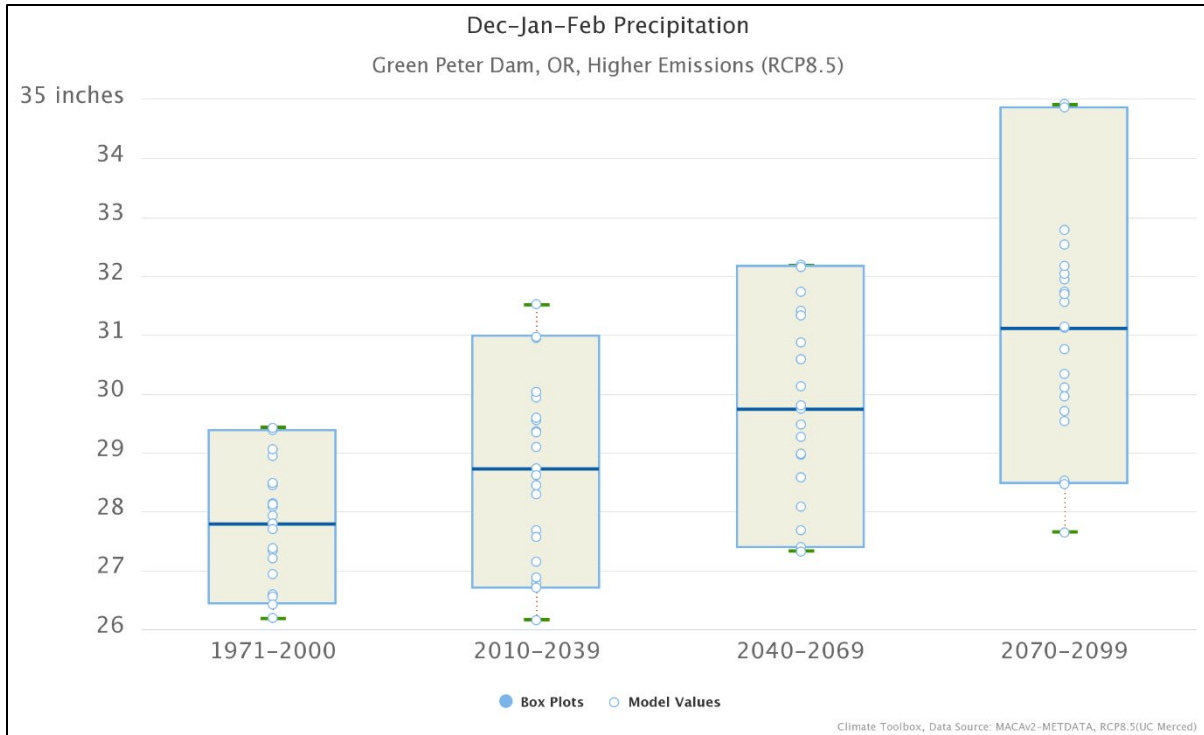


**Figure 3-33. Average Annual Temperature Trends at Green Peter Dam, Oregon, 1950–2100.**

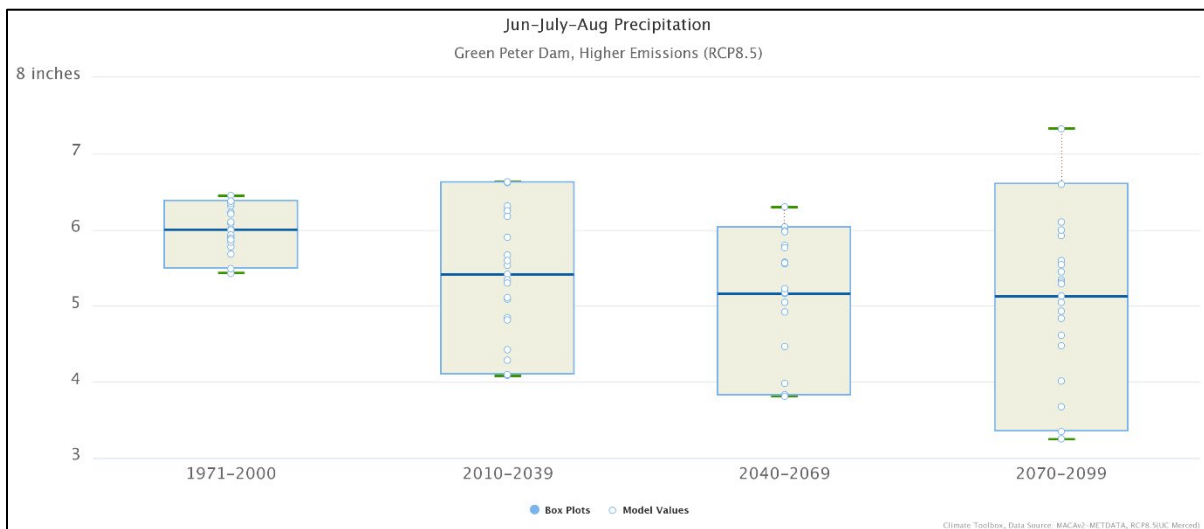


**Figure 3-34. Average Annual Summer Temperature Trends at Green Peter Dam, Oregon, 1950–2100.**

*Willamette Valley System Operations and Maintenance  
Environmental Impact Statement*



**Figure 3-35. Median Winter Precipitation Trends at Green Peter Dam, Oregon, 1950–2100.**



**Figure 3-36. Median Summer Precipitation Trends at Green Peter Dam, Oregon, 1950–2100.**

The South Santiam River Subbasin (headwater site) pattern is very similar to the adjoining North Santiam River Subbasin. Green Peter Dam unregulated, naturalized hydrographs show the effect of warming temperatures—transitioning a snow-impacted basin to an entirely rainfall-dominated basin by the middle and end of the century. The dominant signal is streamflow volume shifting from a winter and spring distribution to one almost entirely occurring in winter. This has substantial implications for hydro-regulation operations in the future. For example, an operational shift to an earlier refill date may work in the short term, but

*Willamette Valley System Operations and Maintenance  
Environmental Impact Statement*

it may be rendered ineffectual considering projected increases in winter volume and an earlier seasonal refill period projected further into the 21st century. WVS operational response to climate change will need to be adaptative, and future regulation would benefit from enhanced forecast and operational flexibility.

The projected precipitation changes in the South Santiam River Subbasin point to higher expected rainfall in the winter with declines in the summer. Streamflow projections track the future precipitation trends. SWE, already declining, is likely to become non-existent by the end of the century. The Green Peter Dam unregulated summary hydrographs highlighting the 10th (more frequent, low flows), 50th (median) and 90th (less frequent, high flows) exceedance percentiles are shown in Figure 3-37 for Green Peter Dam. Foster Dam downstream follows a similar trend to Green Peter Dam.

Willamette Valley System Operations and Maintenance  
Environmental Impact Statement

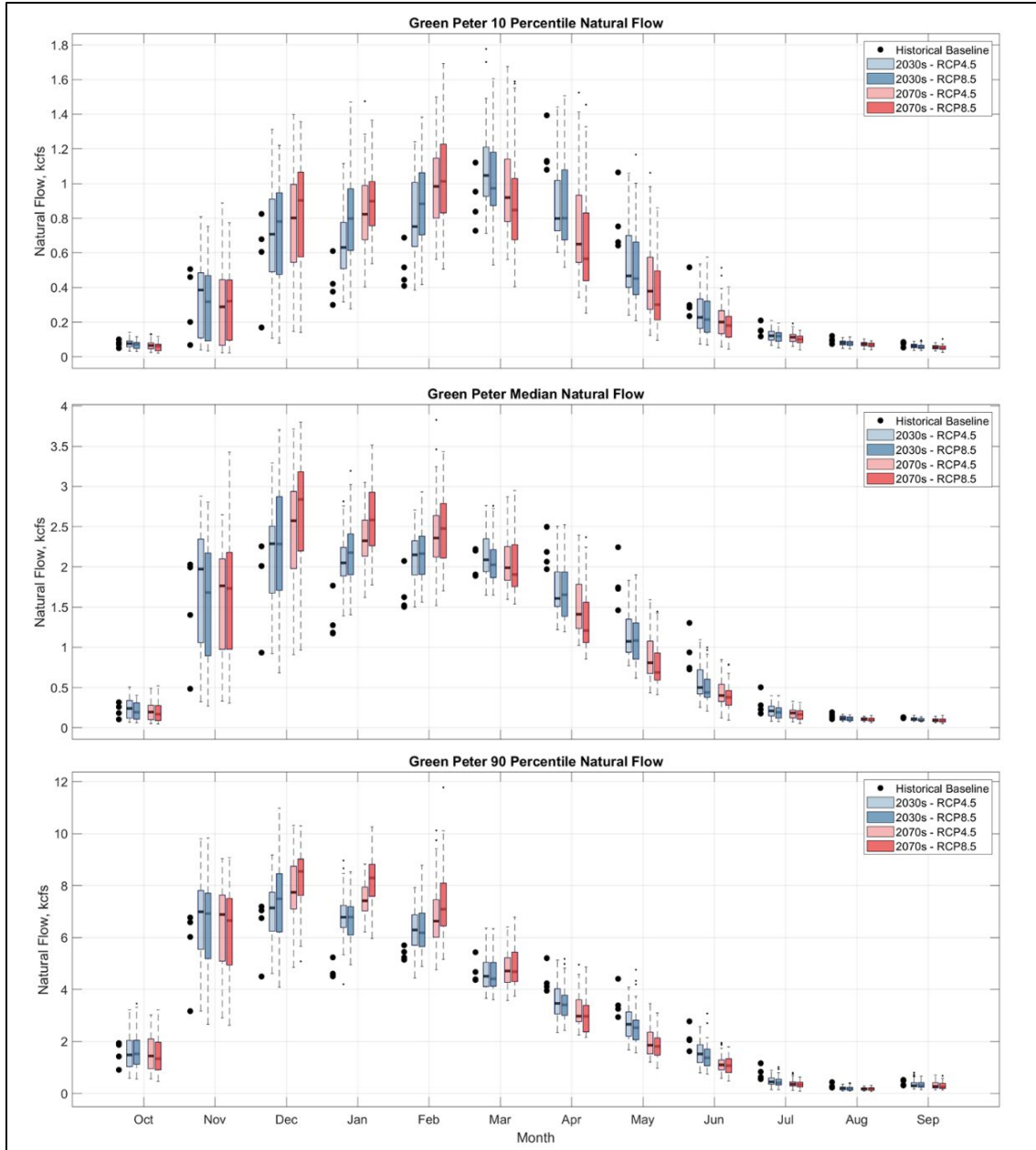


Figure 3-37. South Santiam River at Green Peter Dam, Oregon Summary Hydrographs.

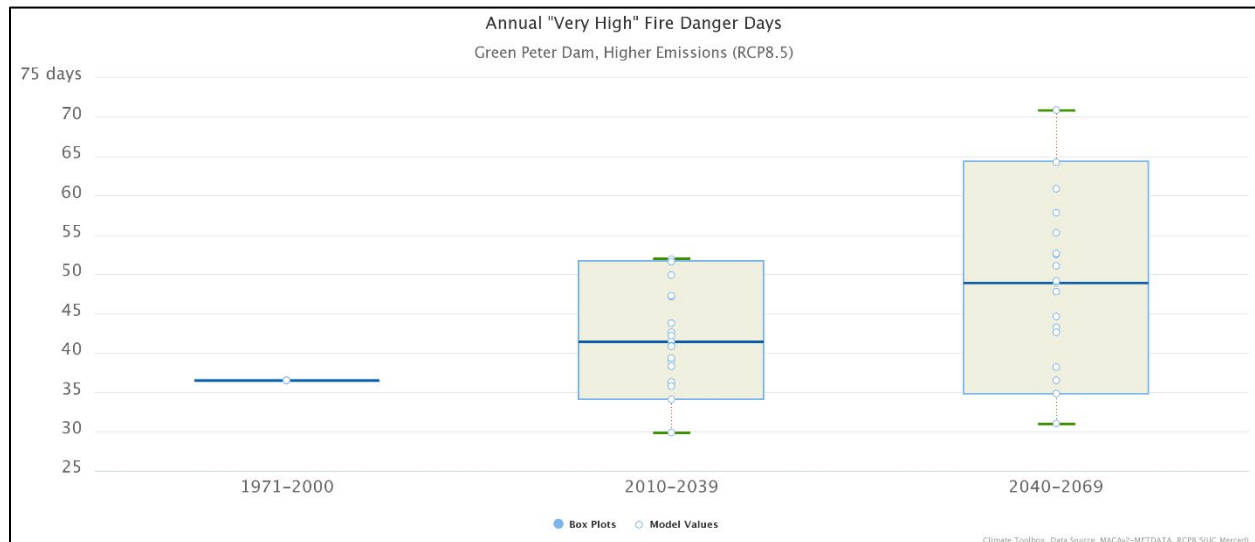
*Willamette Valley System Operations and Maintenance  
Environmental Impact Statement*

**Table 3-4. Green Peter Dam Flow Change.**

GPR Median change - RCP 8.5 2030s and 2070s vs Historical baseline (1976-2005)						
Month	10th Percentile kcfs		Median kcfs		90th Percentile kcfs	
	2030s	2070s	2030s	2070s	2030s	2070s
Oct	-0.005	-0.01	-0.05	-0.05	0	-0.1
Nov	0.01	0.01	0.3	0.45	1	1
Dec	0.19	0.3	0.8	1.3	1.5	3.3
Jan	0.39	0.49	0.55	1.05	1.8	3.1
Feb	0.29	0.41	0.35	0.74	0.5	1.4
Mar	0.05	-0.09	-0.1	-0.25	-0.8	-0.5
Apr	-0.4	-0.61	-0.65	-1.05	-0.7	-1.2
May	-0.33	-0.45	-0.65	-1.15	-1.3	-1.6
Jun	-0.1	-0.11	-0.5	-0.55	-0.5	-1
Jul	-0.03	-0.04	-0.05	-0.1	-0.6	-0.62
Aug	-0.05	-0.05	-0.1	-0.1	-0.05	-0.05
Sep	-0.02	-0.02	-0.05	-0.07	-0.02	-0.02

The increase in winter flows is indicated by the November through March, median flow increase. Contrasting with the pattern seen in the valley floor, Green Peter Dam, OR summary hydrographs portray the different streamflow patterns of a snowpack-affected basin. The historical pattern is for an annual peak in the winter (DJF) followed by a lesser annual rise from the snow melt pulse peaking in May.

The future pattern will reflect higher winter volume and a diminished (or eliminated) spring runoff. It is likely that change in timing and quantity will complicate water management in the Willamette Valley. Operational approaches should consider potential effects from these projected changes to effectively navigate likely changes in the future.



**Figure 3-38. Green Peter Dam, Oregon Annual Very High Fire Danger Days.**

As shown in Figure 3-38, Green Peter Dam and surrounding areas are likely to experience higher fire risk in the future. Median change is upward for both future epochs. The variability of

the fire risk days (between GCM models) is greater in the upland basins, in contrast to the valley floor sites, such as Salem and Albany.

### 3.2.8 McKenzie River Subbasin

The McKenzie River Subbasin is approximately 1,345 square miles. Over three quarters of the basin is steep, mountainous, and forested. The subbasin average elevation is approximately 3,140 feet (NAVD88), the high point adjacent to McKenzie Pass is about 10,309 feet (NAVD88), and the minimum elevation is 316 feet (NAVD88) close to the basin terminus at Springfield, OR.

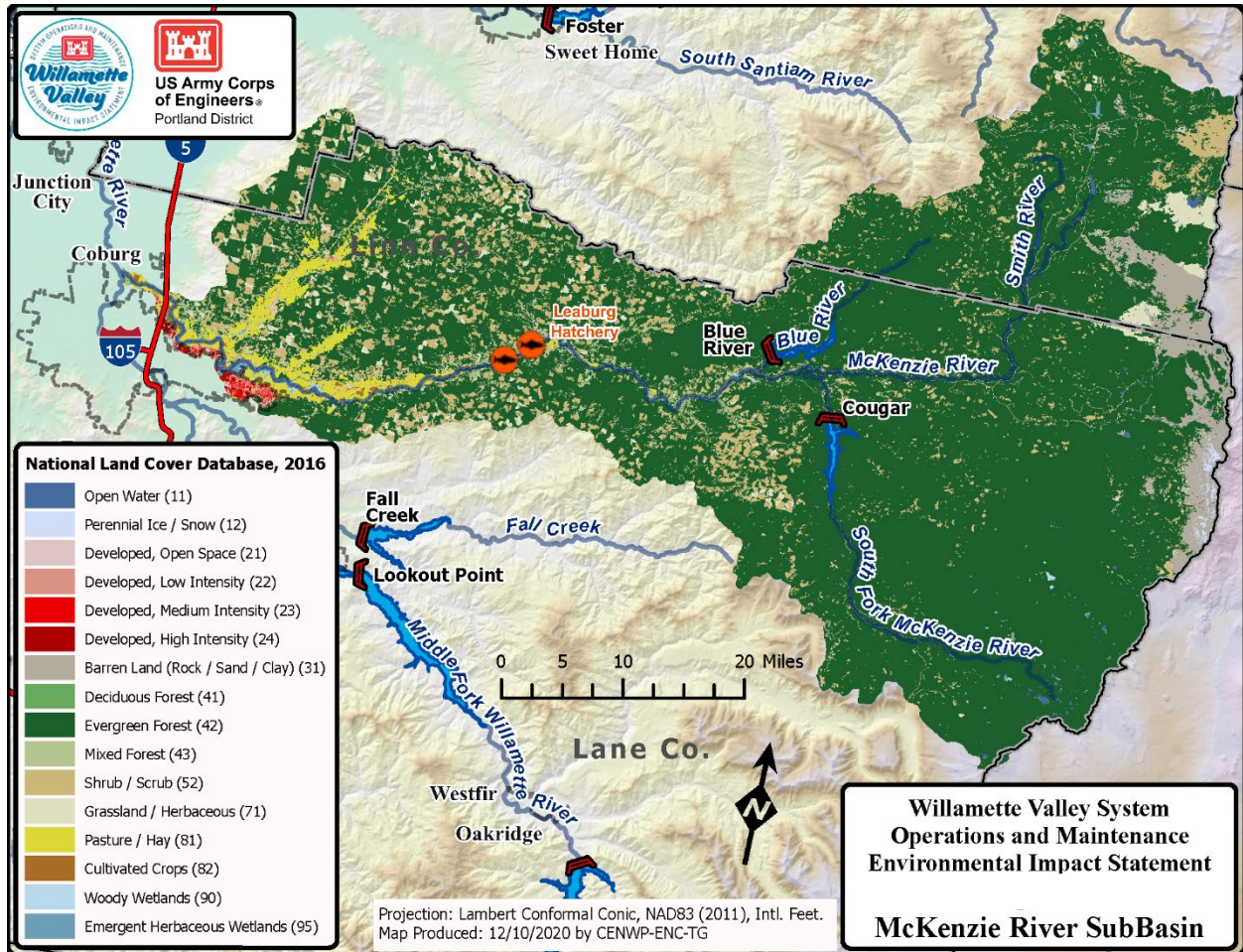
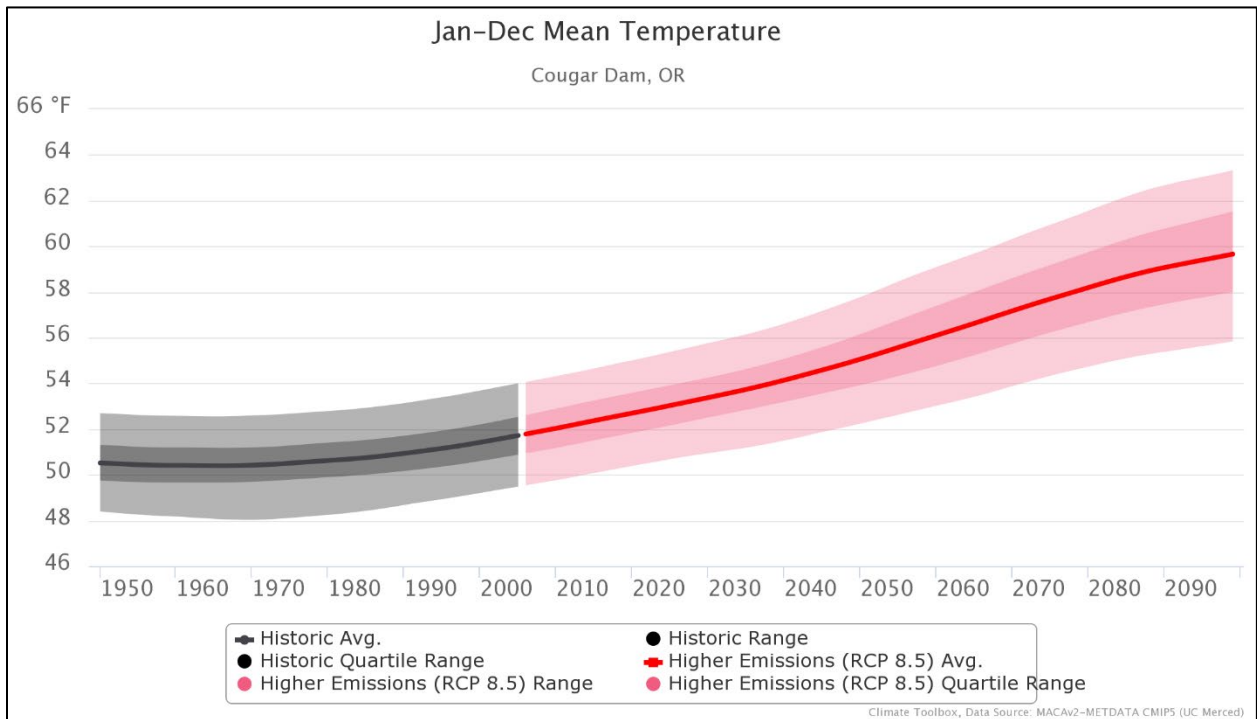


Figure 3-39. McKenzie River Subbasin.

The two USACE projects in the McKenzie River Subbasin are Cougar Dam on the South Fork McKenzie River and Blue River Dam on the Blue River, a tributary to the McKenzie River. Cougar Dam is a multi-use project, primarily power (i.e., 25 MW), recreation, and flood risk reduction. ESA-listed spring Chinook salmon, Oregon chub, and bull trout are present in the subbasin. A water temperature control structure at Cougar Dam began operation in May 2005 and provides cooler downstream flows to improve spring Chinook salmon production.

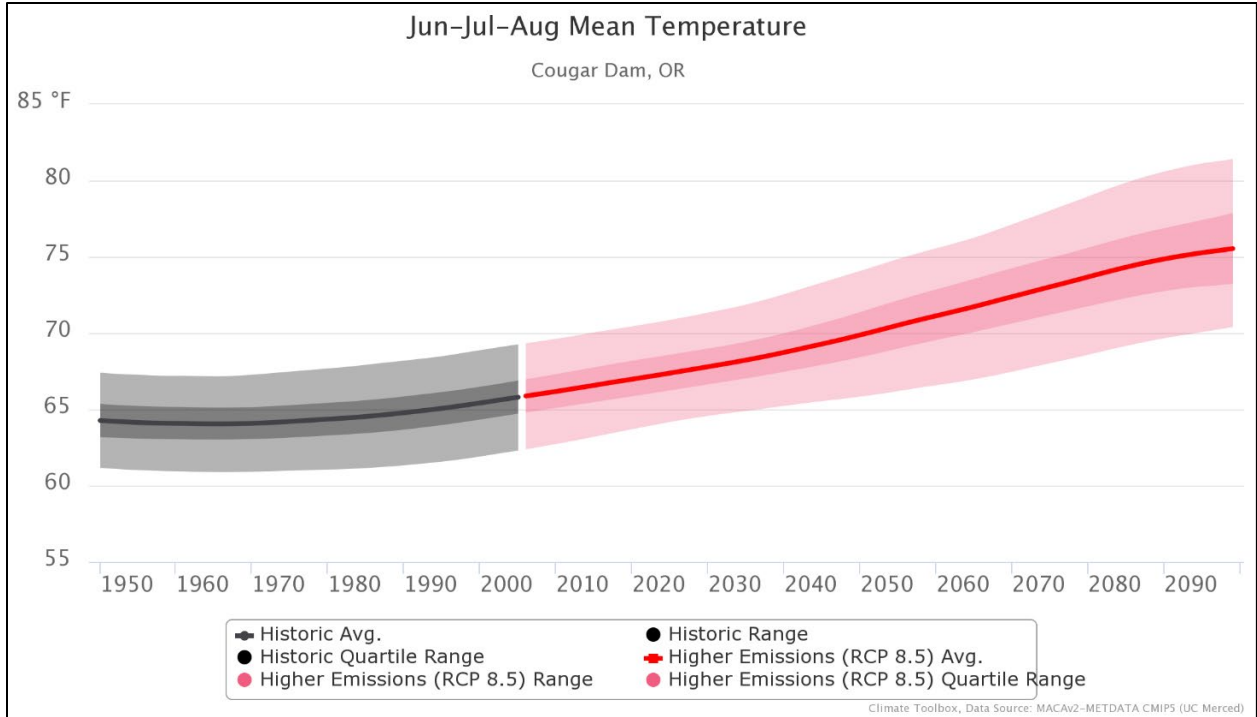
*Willamette Valley System Operations and Maintenance  
Environmental Impact Statement*

Figure 3-40 and Figure 3-41 depict the average annual and summer (JJA) air temperature changes at Cougar Dam. As the subbasin experiences increased warming, there will likely be impacts to future temperature operations at Cougar Dam. Blue River Dam is operated with Cougar Dam to facilitate flood risk management locally to Springfield/Eugene and downstream system control points. Water temperature control measures at Blue River Dam have been determined to be not feasible. There are two hatcheries in the subbasin located at Leaburg, OR and downstream on the McKenzie River mainstem.

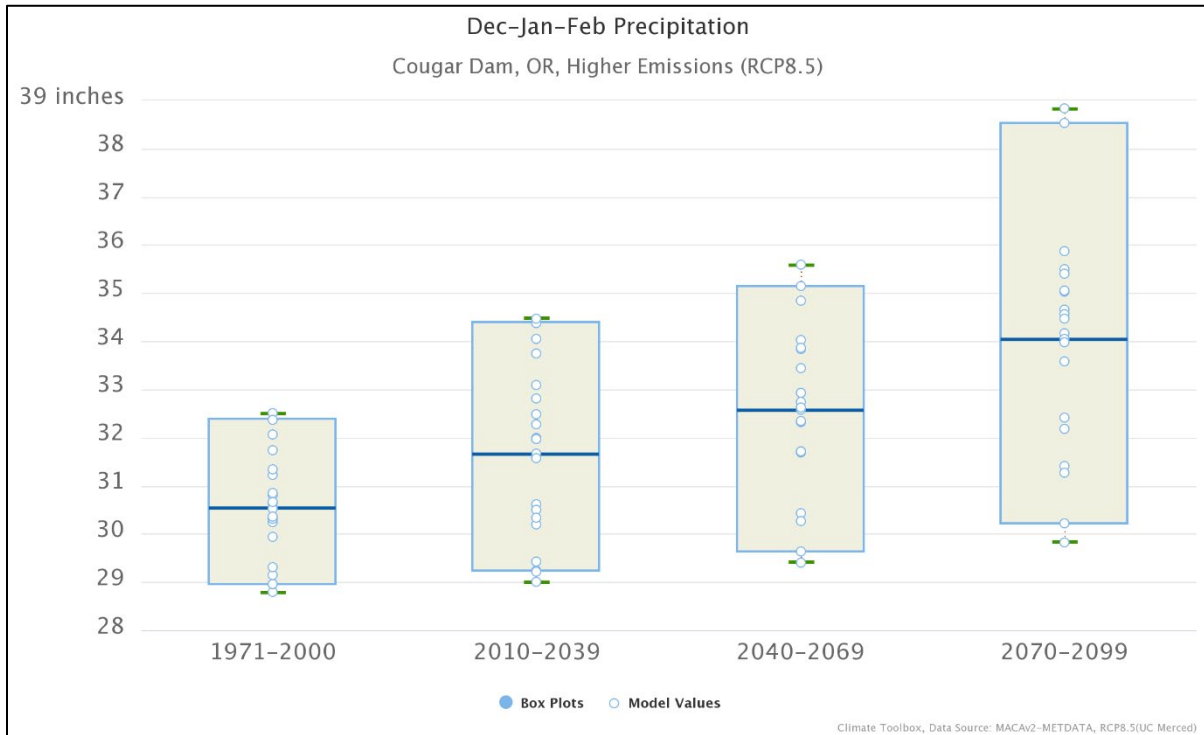


**Figure 3-40. Average Annual Temperature Trends at Cougar Dam, Oregon, 1950–2100.**

Willamette Valley System Operations and Maintenance  
Environmental Impact Statement



**Figure 3-41. Average Annual Summer Temperature Trends at Cougar Dam, Oregon, 1950–2100.**



**Figure 3-42. Median Winter Precipitation Trends at Cougar Dam, Oregon, 1950–2100.**

Willamette Valley System Operations and Maintenance  
Environmental Impact Statement

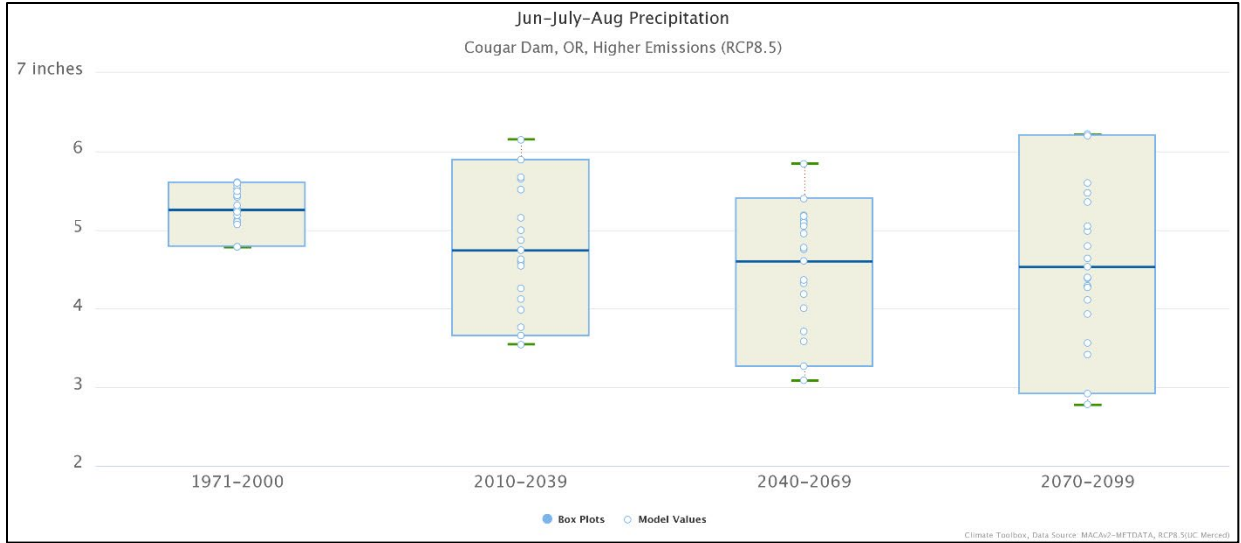


Figure 3-43. Median Summer Precipitation Trends at Cougar Dam, Oregon, 1950–2100.

Willamette Valley System Operations and Maintenance  
Environmental Impact Statement

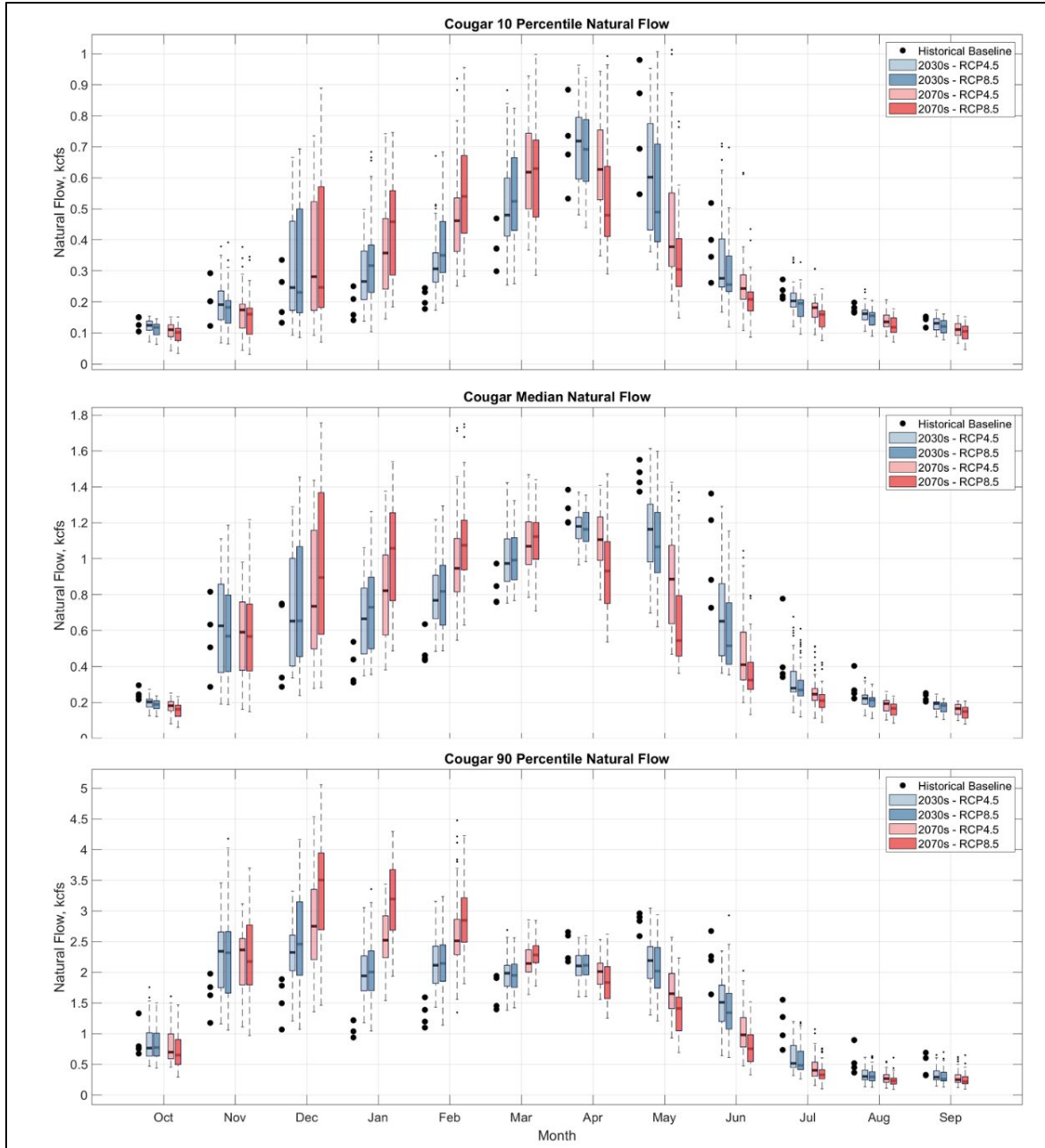
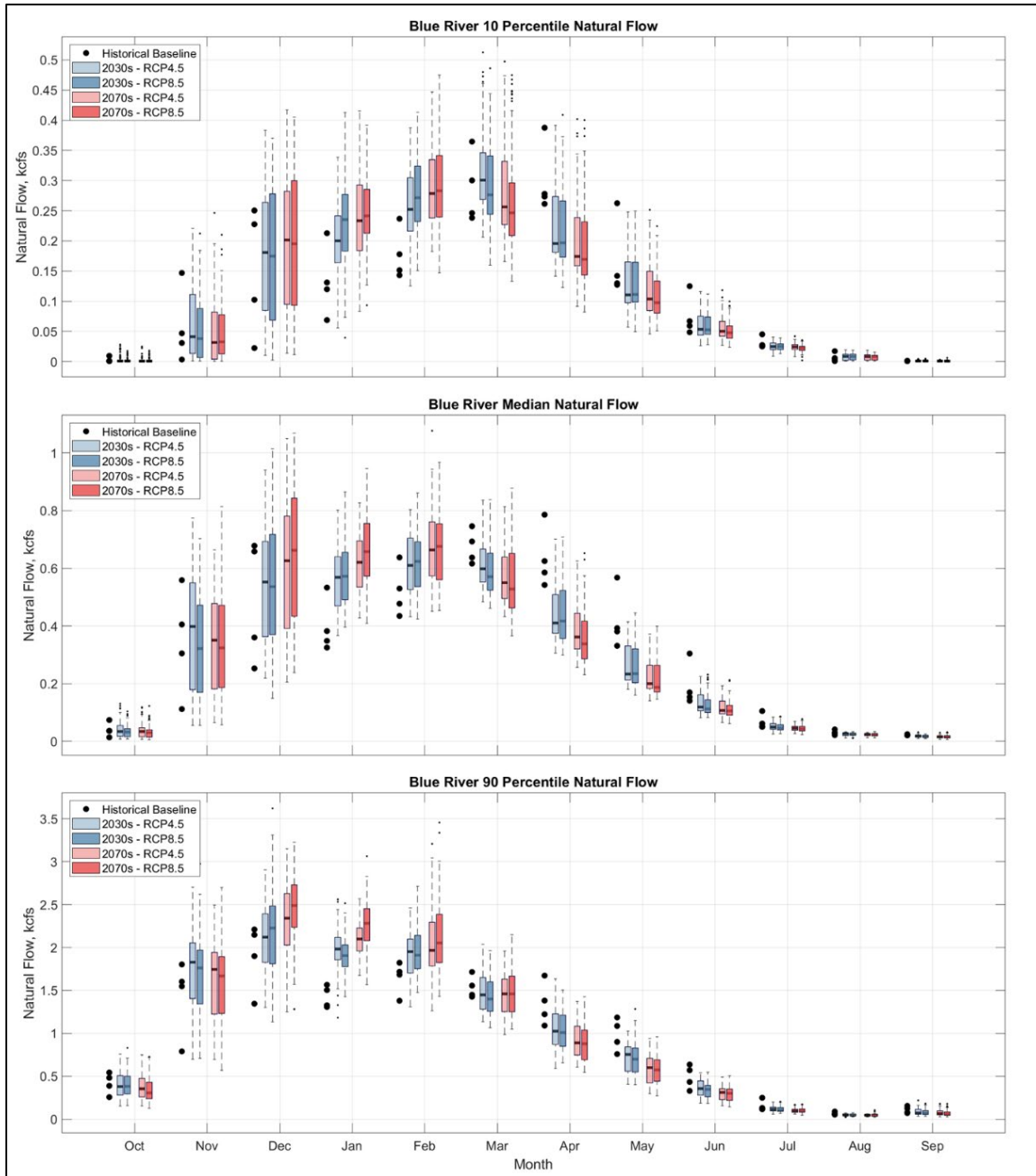


Figure 3-44. McKenzie River at Cougar Dam, Oregon Summary Hydrographs.

*Willamette Valley System Operations and Maintenance  
Environmental Impact Statement*



**Figure 3-45. Blue River Dam, Oregon Summary Hydrographs.**

Overall, the McKenzie River Subbasin (at Cougar Dam and Blue River Dam) future hydroclimate and hydrology trends are similar to that seen in the Santiam River Subbasins. Both Cougar Dam and Blue River Dam hydrographs show the effect from warming temperatures—transitioning from a snow-impacted basin to a rainfall-dominated basin. The dominant signal is streamflow volume shifting from a winter and spring distribution to one almost entirely occurring in winter. Table 3-5 and Table 3-6 summarize the relative change in flows for the 10th, 50th, and 90th percentile flows for Cougar and Blue River Dams, respectively.

Willamette Valley System Operations and Maintenance  
Environmental Impact Statement

**Table 3-5. Cougar Dam Flow Change.**

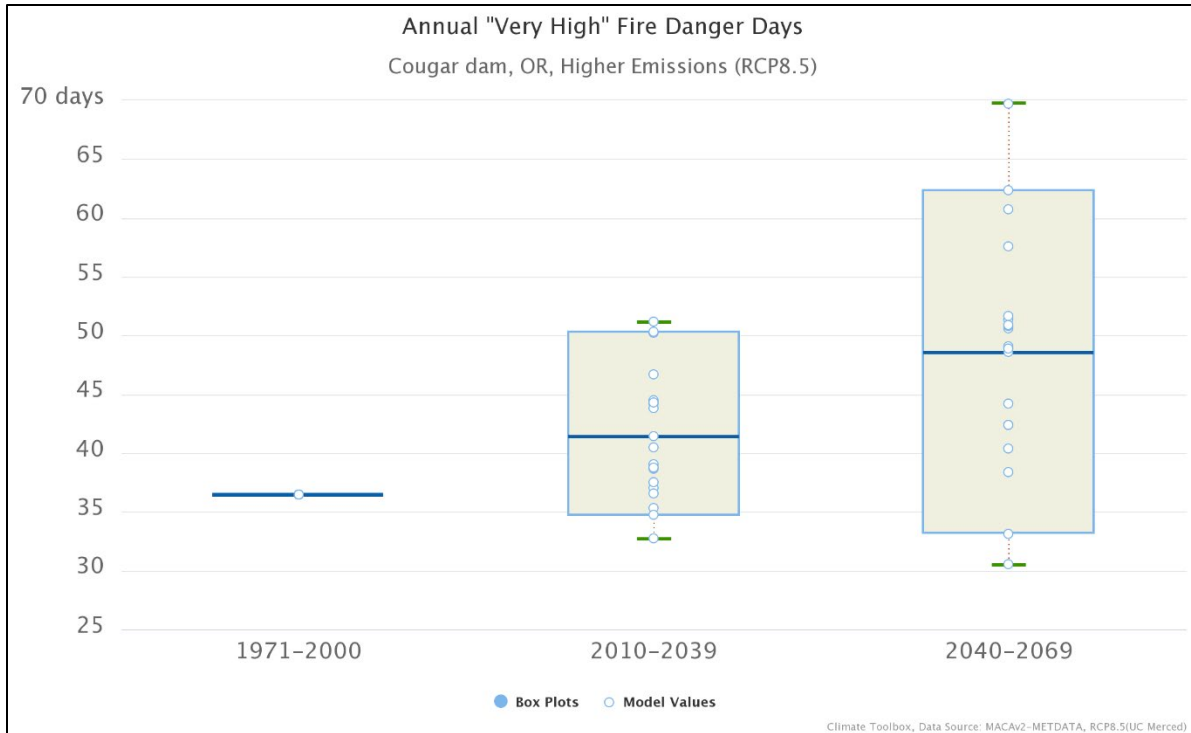
CGR Median change - RCP 8.5 2030s and 2070s vs Historical baseline (1976-2005)						
Month	10th Percentile kcfs		Median kcfs		90th Percentile kcfs	
	2030s	2070s	2030s	2070s	2030s	2070s
Oct	-0.01	-0.05	-0.02	-0.04	-0.25	-0.4
Nov	-0.01	-0.02	0	0	0.85	0.5
Dec	-0.01	0.02	0.06	0.34	0.89	1.9
Jan	0.08	0.28	0.38	0.68	0.9	2.25
Feb	0.14	0.33	0.35	0.62	0.8	1.5
Mar	0.14	0.24	0.39	0.37	0.25	0.55
Apr	-0.01	-0.21	-0.08	-0.3	-0.3	-0.6
May	-0.29	-0.48	-0.34	-0.84	-0.8	-1.35
Jun	-0.14	-0.19	-0.51	-0.71	-0.7	-1.45
Jul	-0.05	-0.07	-0.2	-0.27	-0.6	-0.75
Aug	-0.02	-0.06	-0.06	-0.09	-0.25	-0.35
Sep	-0.02	-0.03	-0.02	-0.03	-0.25	-0.3

**Table 3-6. Blue River Dam Flow Change.**

BLU Median change - RCP 8.5 2030s and 2070s vs Historical baseline (1976-2005)						
Month	10th Percentile kcfs		Median kcfs		90th Percentile kcfs	
	2030s	2070s	2030s	2070s	2030s	2070s
Oct	-0.004	-0.004	-0.04	-0.04	-0.08	-0.18
Nov	-0.02	0.025	-0.06	-0.06	0.33	0.23
Dec	0.03	0.05	0.07	0.14	0.74	0.99
Jan	0.09	0.1	0.18	0.23	0.42	0.77
Feb	0.07	0.1	0.1	0.17	0.27	0.47
Mar	-0.01	-0.04	-0.09	-0.11	-0.16	-0.07
Apr	-0.1	-0.13	-0.21	-0.25	-0.35	-0.55
May	-0.07	-0.07	-0.21	-0.23	-0.3	-0.49
Jun	-0.03	0.035	-0.06	-0.11	-0.08	-0.03
Jul	-0.02	-0.02	-0.3	-0.3	-0.15	-0.15
Aug	0.006	0.006	-0.05	-0.05	-0.05	-0.05
Sep	0.002	0.002	-0.03	-0.03	-0.1	-0.1

The increase in winter high flows (P90) is indicated by the November through March relative increases in P90 median flows. Contrasting with the pattern seen in the valley floor, Cougar, OR and Blue River summary hydrographs portray the different streamflow patterns of a snowpack-affected basin. The historical pattern is for an annual peak in the winter (DJF) followed by a lesser annual rise from the snow melt pulse peaking in May.

The future pattern will reflect higher winter volume and a diminished (or eliminated) spring runoff. This change in timing and quantity will complicate traditional hydro-regulation practices in the Willamette Valley. Operational approaches should consider potential effects from these projected changes to effectively navigate likely changes in the future.



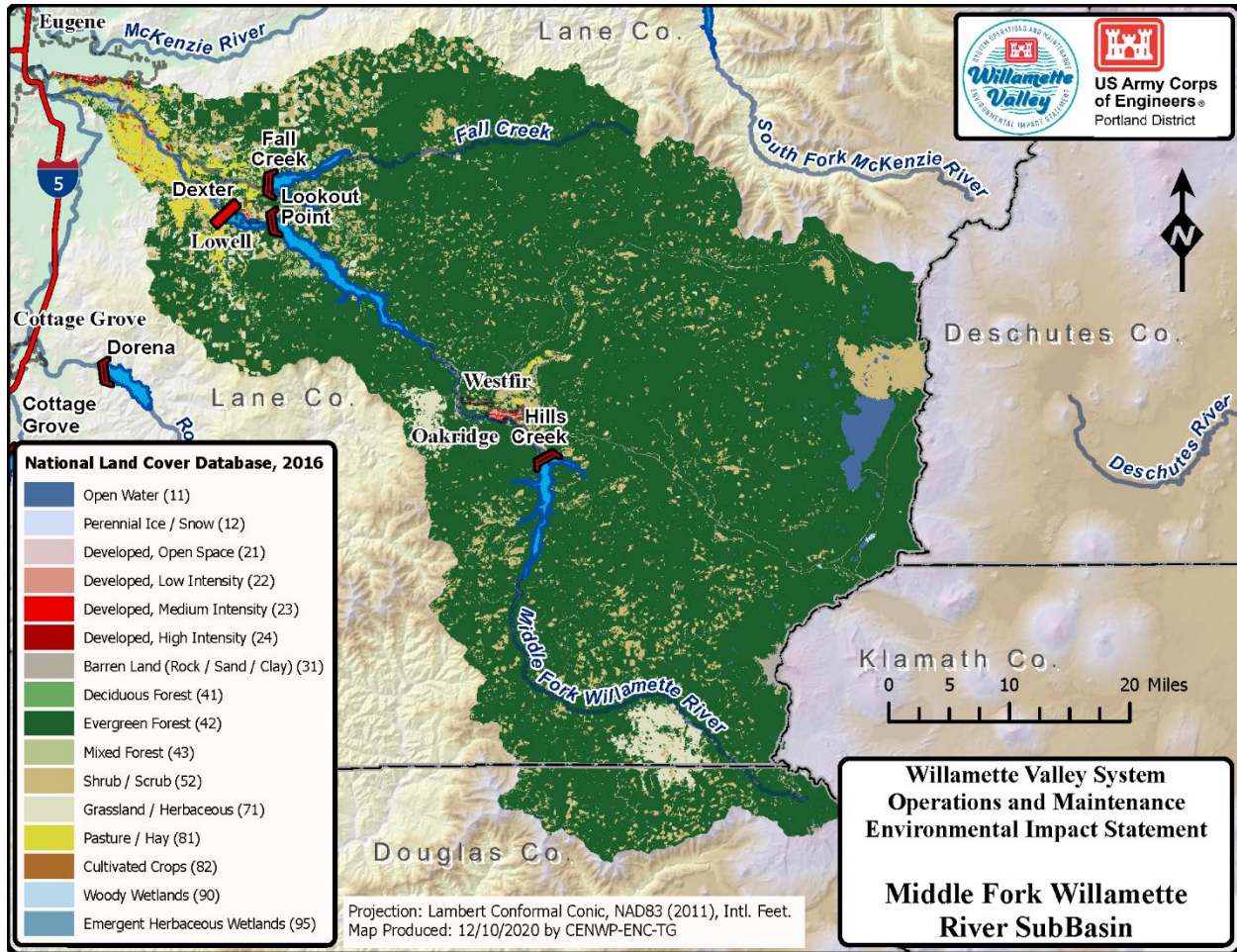
**Figure 3-46. Cougar Dam, Oregon Annual Very High Fire Danger Days.**

The fire risk at Cougar Dam, OR is chosen as representative for the subbasin. Blue River high fire risk day trends would be similar in magnitude and variability. Again, there is a distinct median increase, suggesting an increasing fire hazard in the future.

### 3.2.9 Middle Fork Willamette River Subbasin

The Middle Fork (MF) Willamette River Subbasin is approximately the same size as the McKenzie River Subbasin at 1,366 square miles. Similarly, the majority (over 3/4) of the subbasin's topography is steep, mountainous, and forested. However, the Middle Fork Willamette River Subbasin is at a lower average elevation at approximately 3,270 feet (NAVD88). The subbasin high point is about 8,710 feet (NAVD88) while the minimum elevation is 152 feet (NAVD88). The subbasin outlets at Interstate 5 just upstream (south) of Eugene, Oregon and contains very little urban area.

*Willamette Valley System Operations and Maintenance  
Environmental Impact Statement*



**Figure 3-47. Middle Fork Willamette River Subbasin.**

The Middle Fork Willamette River Subbasin contains four USACE projects. Hills Creek, Lookout Point, and Dexter Dams are located on the MF Willamette River. Hills Creek Dam is the most upstream project on the MF Willamette River, and Fall Creek Dam is on Fall Creek, tributary to the MF Willamette River. Currently, ESA-listed spring Chinook salmon and bull trout are present in the subbasin. Hills Creek and Lookout Point Dams are multipurpose projects operated in tandem and storage between the two projects is generally balanced to capture floodwater during the winter and spring months. In summer, storage from these projects is used extensively to meet minimum flow requirements on the mainstem Willamette River.

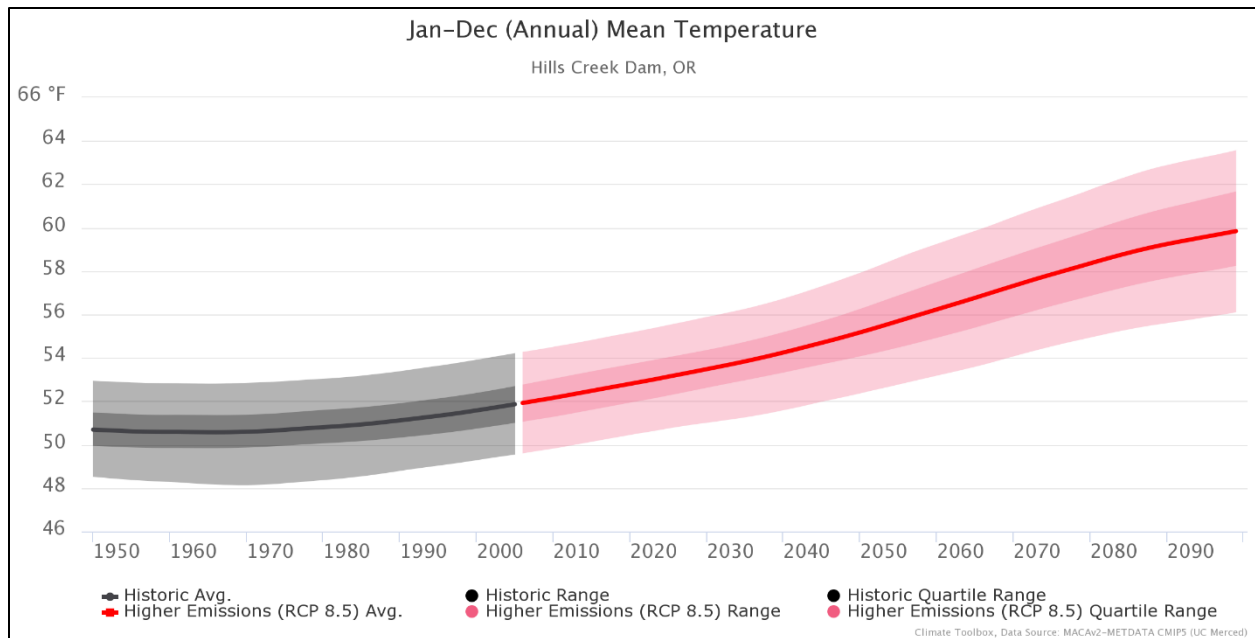
Hills Creek Dam has two turbines capable of producing 15 MW each and Lookout Point Dam has three turbines capable of producing 40 MW each. Dexter Dam is a re-regulation project located downstream of Lookout Point Dam and is used to control water levels created by peak hydropower generation at Lookout Point Dam. There is one turbine unit at Dexter Dam that produces 15 MW of power. Dexter Reservoir is heavily used for recreation in summer. Fall Creek Dam and Reservoir is a multipurpose project that does not have a powerhouse, and this reservoir also is heavily used for recreation in summer.

*Willamette Valley System Operations and Maintenance  
Environmental Impact Statement*

Hydroclimate changes are similar across the MF Willamette River Subbasin. Future annual and seasonal precipitation and temperature trends, as well as trends in high fire risk days, are displayed for the Hills Creek Subbasin to provide insight into climate change impacts in the MF Willamette River. Overall, climate change projections for the future indicate substantial warming in the subbasin. Figure 3-48 and Figure 3-49 portray upward trends annually and in summer. Summer temperature changes are expected to have the greatest relative increases. Figure 3-50 through Figure 3-53 graphically summarize, via statistical box plots, the projected changes in precipitation and ambient temperatures for the critical winter and summer months.

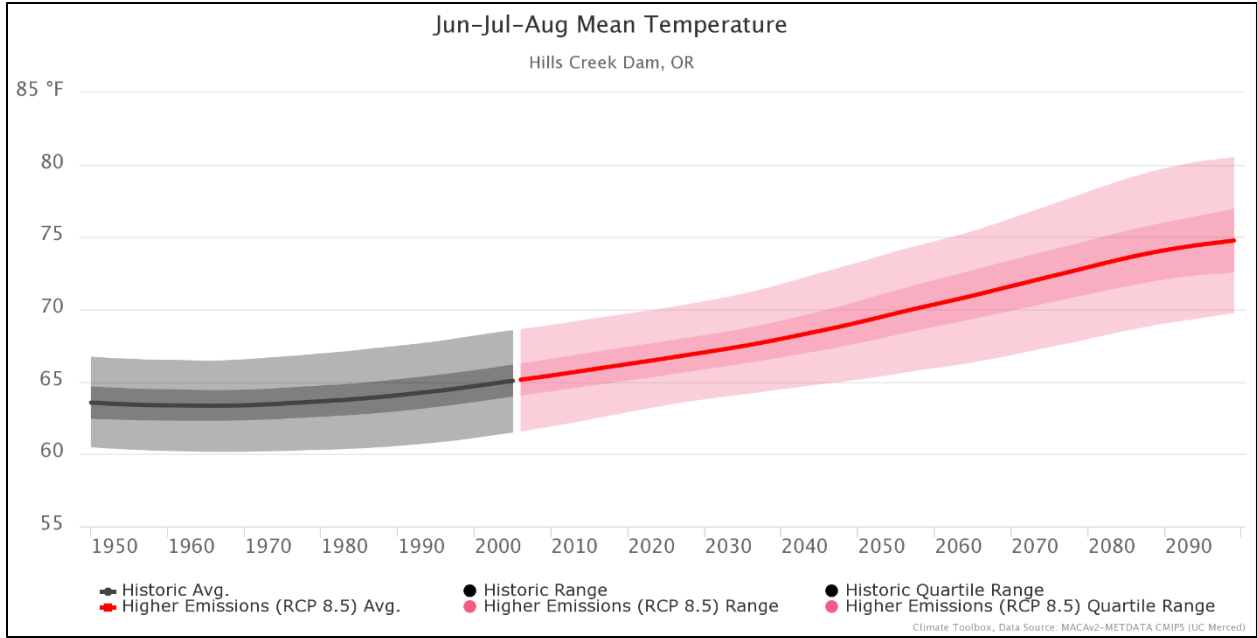
Projected streamflow changes are shown at Lookout Point and Fall Creek Dams. Together, they are considered representative of the greater MF Willamette River Subbasin expected future patterns.

Hills Creek Dam is also shown and represents the more upstream, somewhat higher elevation and more pristine natural conditions subbasin. Fall Creek Dam represents the lower elevation and more downstream rural land-use site. The unregulated naturalized streamflow changes at Hills Creek, Lookout Point, and Fall Creek Dams are shown in Figure 3-54, Figure 3-55, and Figure 3-56. Dexter Dam was not included because of its proximity to Lookout Point Dam.



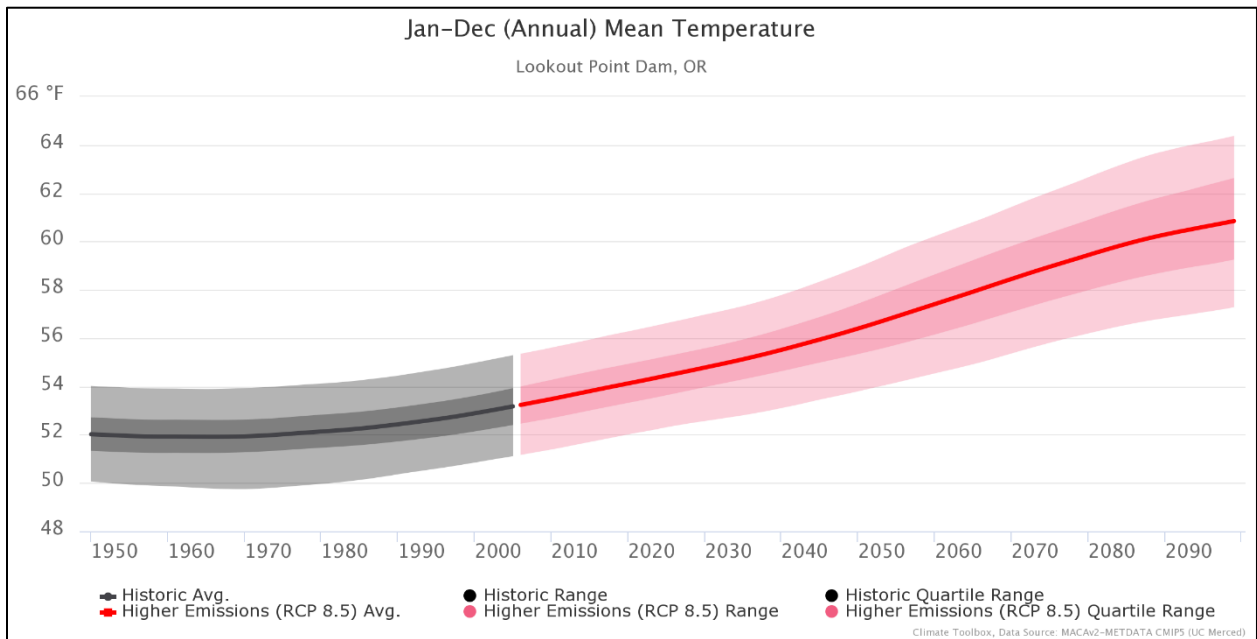
**Figure 3-48. Average Annual Temperature Trends at Hills Creek Dam, Oregon, 1950–2100.**

*Willamette Valley System Operations and Maintenance  
Environmental Impact Statement*



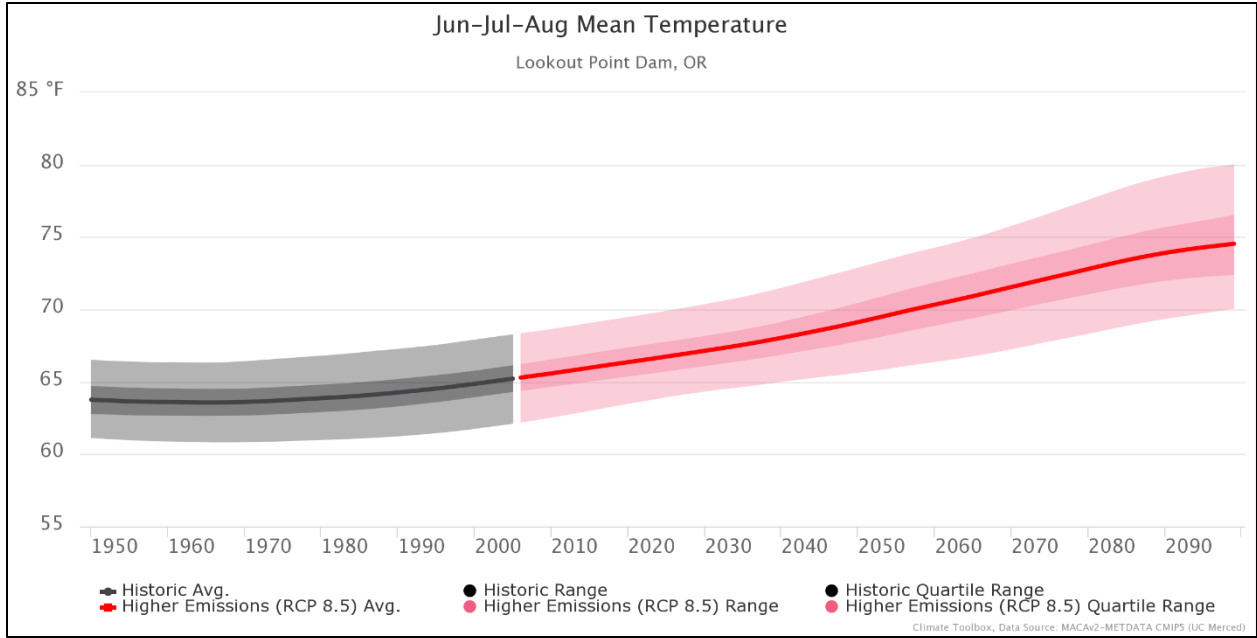
**Figure 3-49. Average Annual Summer Temperature Trends at Hills Creek Dam, Oregon, 1950–2100.**

For contrast, Lookout Point Dam projected temperatures are presented in Figure 3-50 and Figure 3-51. The trends are very similar between Hills Creek and Lookout Point Dams. However, temperature changes presented herein should not be used quantitatively and only to inform a qualitative determination.

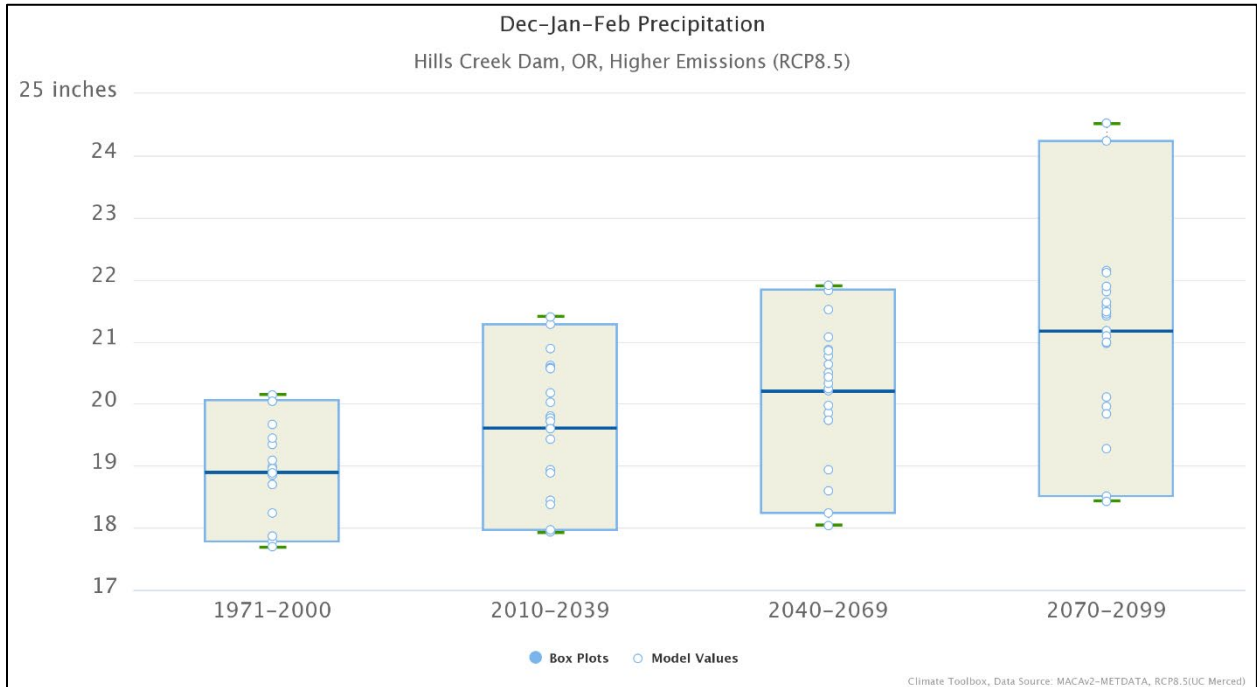


**Figure 3-50. Average Annual Temperature Trends at Lookout Point Dam, Oregon, 1950–2100.**

*Willamette Valley System Operations and Maintenance  
Environmental Impact Statement*



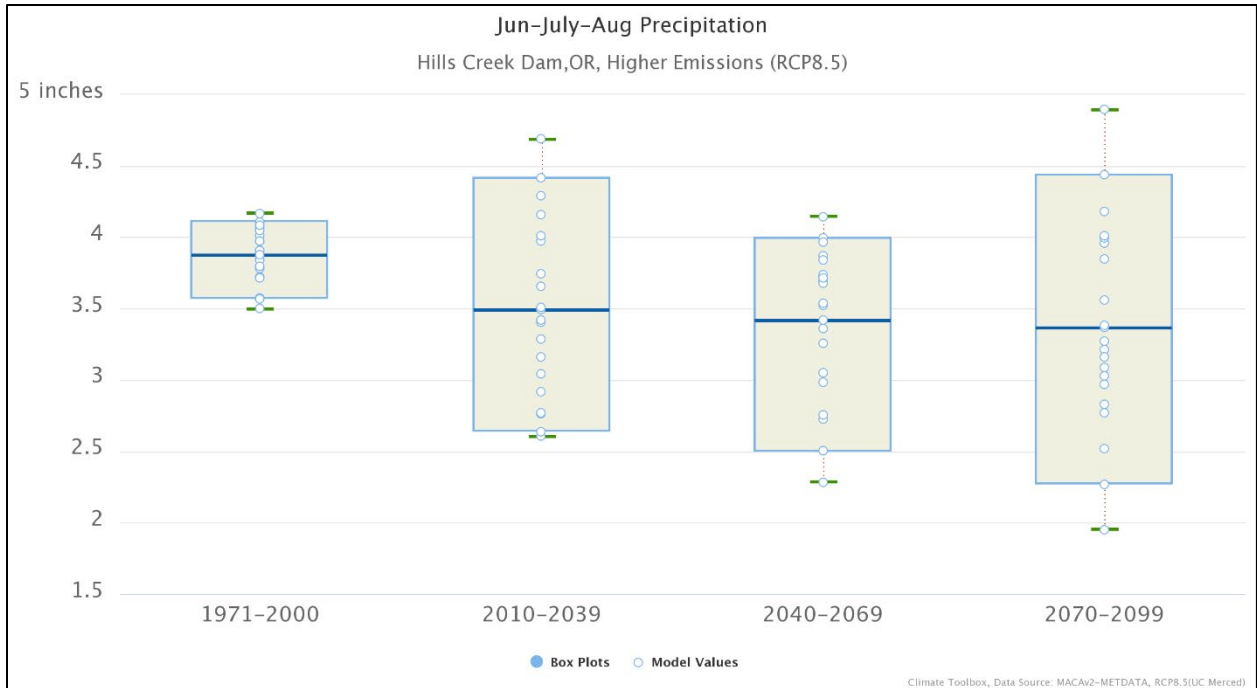
**Figure 3-51. Average Annual Summer Temperature Trends at Lookout Point Dam, Oregon, 1950–2100.**



**Figure 3-52. Median Winter Precipitation Trends at Hills Creek Dam, Oregon, 1950–2100.**

Source: Northwest Climate Toolbox

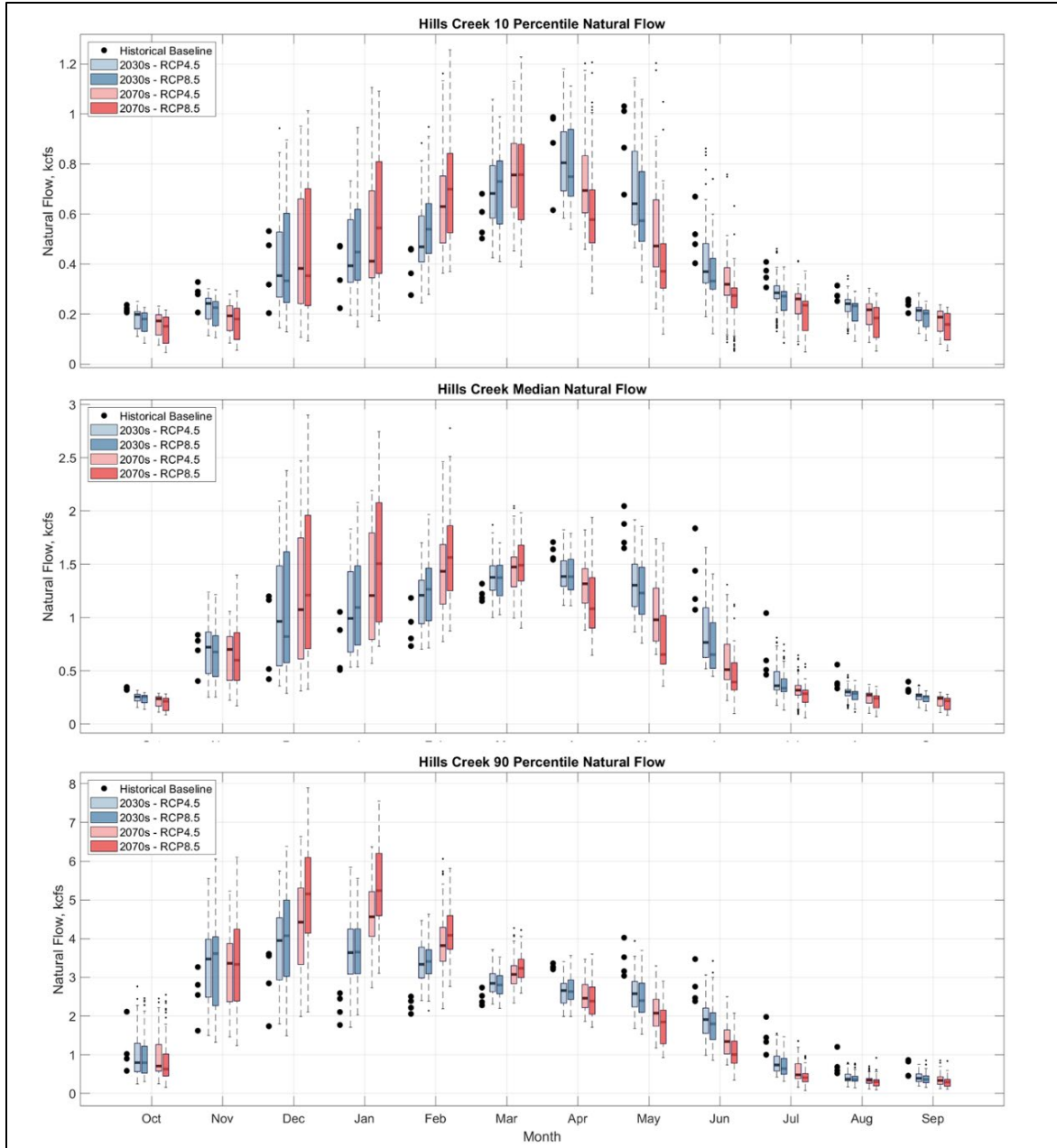
Willamette Valley System Operations and Maintenance  
Environmental Impact Statement



**Figure 3-53. Median Summer Precipitation Trends at Hills Creek Dam, Oregon, 1950–2100.**

Overall, the MF Willamette River Subbasin projected climate change patterns correspond to the trends projected for the rest of the Willamette River Basin. The summary hydrograph plots exemplify the effect from warming temperatures—transitioning from a snow-impacted basin to a fully rainfall-dominated basin. The dominant signal is streamflow volume shifting from a winter and spring distribution to one almost entirely occurring in winter. As shown below, this has implications for hydro-regulation operations in the future. Even though these are unregulated flows, the relatively higher percentage of change noted above could conceptually complicate the hydro-regulation.

*Willamette Valley System Operations and Maintenance  
Environmental Impact Statement*



**Figure 3-54. MF Willamette River at Hills Creek Dam, Oregon Summary Hydrographs.**

Willamette Valley System Operations and Maintenance  
Environmental Impact Statement

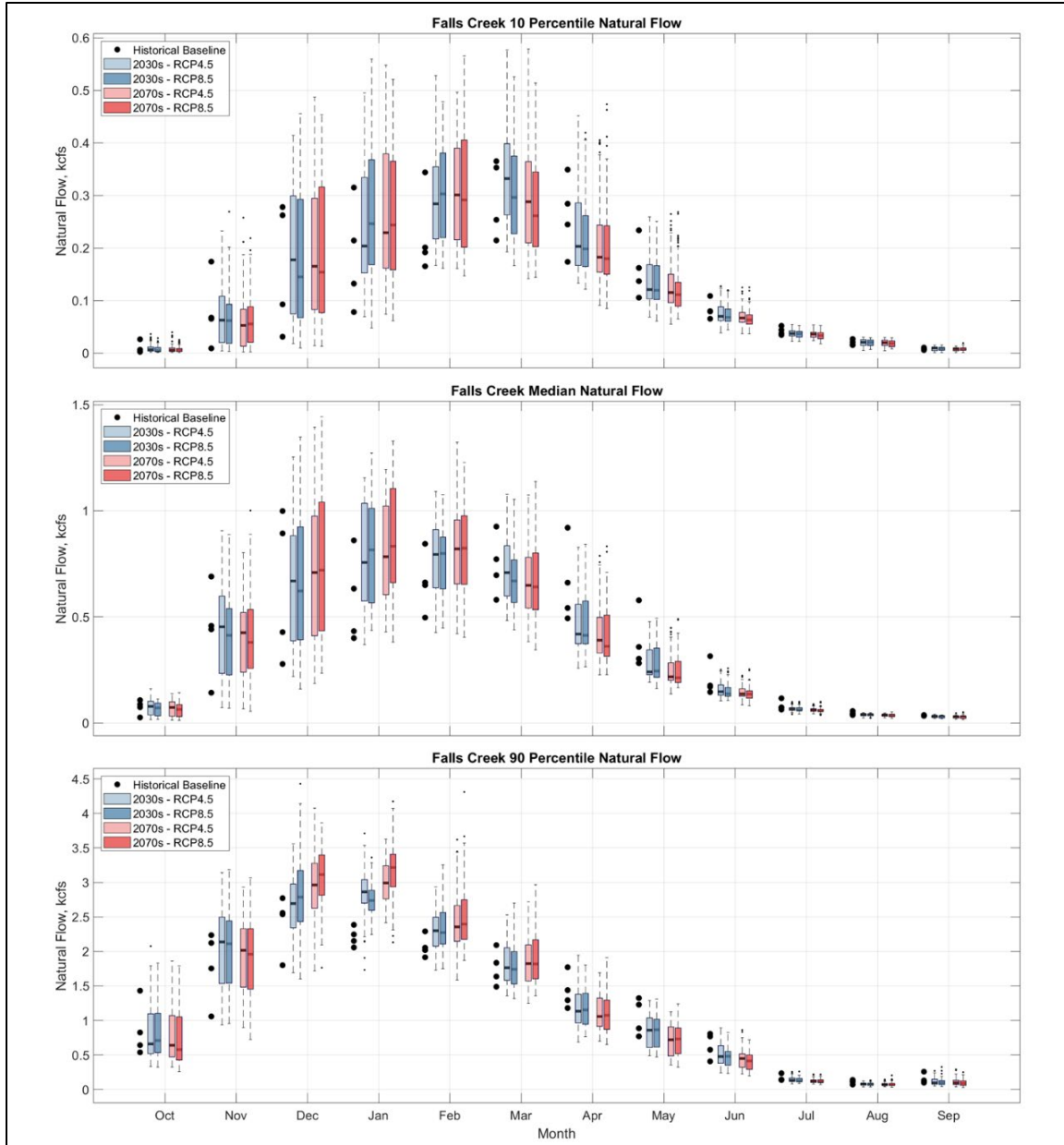
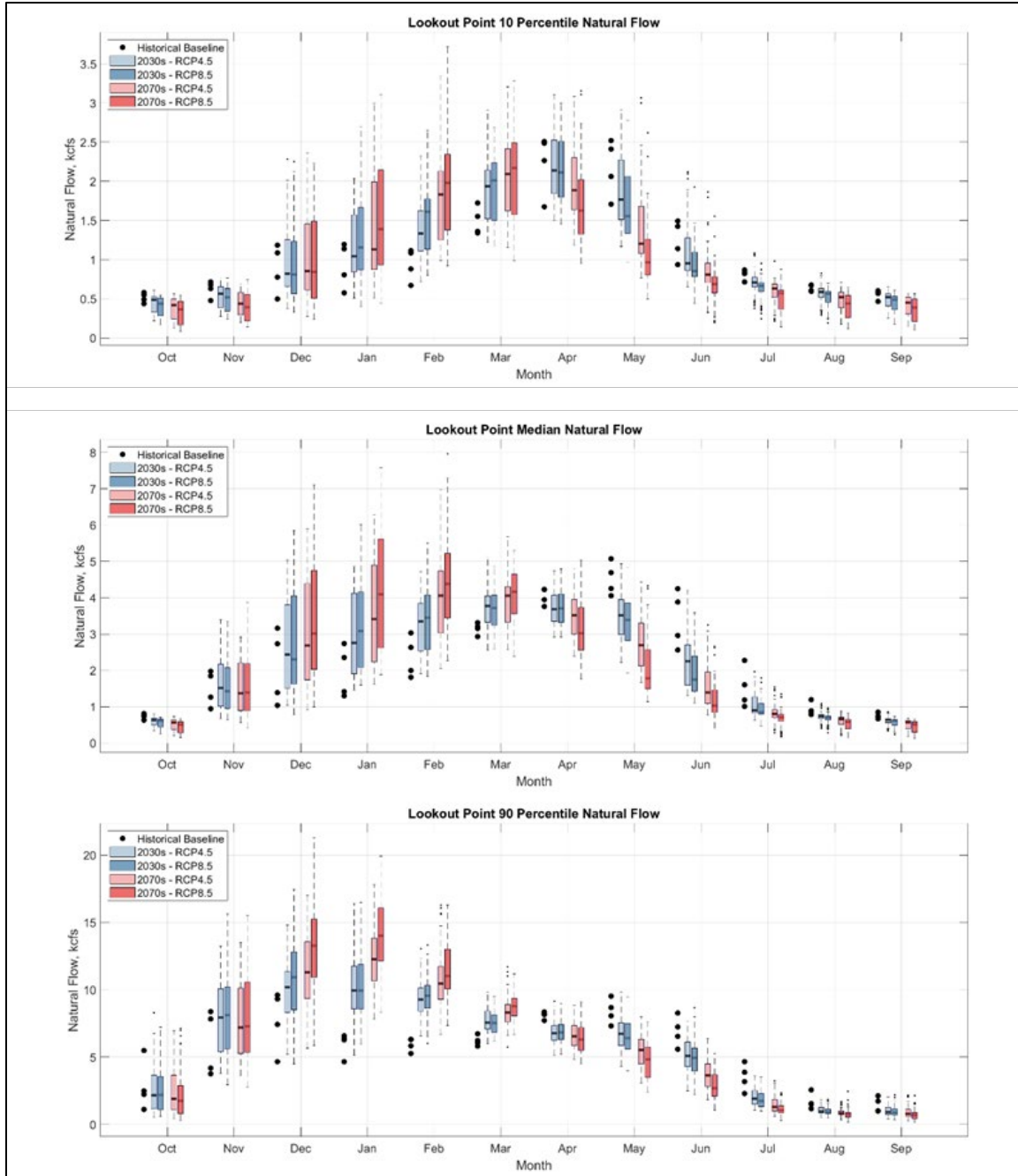


Figure 3-55. Fall Creek Dam, Oregon Summary Hydrographs.

*Willamette Valley System Operations and Maintenance  
Environmental Impact Statement*



**Figure 3-56. MF Willamette River at Lookout Point Dam, Oregon Summary Hydrographs.**

Table 3-7 through Table 3-9 summarize the relative change in flows for the 10th, 50th, and 90th percentile flows for Cougar and Blue River Dams, respectively.

Willamette Valley System Operations and Maintenance  
Environmental Impact Statement

**Table 3-7. Hills Creek Dam Flow Change.**

HCR Median change - RCP 8.5 2030s and 2070s vs Historical baseline (1976-2005)						
Month	10th Percentile kcfs		Median kcfs		90th Percentile kcfs	
	2030s	2070s	2030s	2070s	2030s	2070s
Oct	-0.02	-0.03	-0.1	-0.05	-0.5	-0.7
Nov	-0.08	-0.11	0.025	0.125	1	0.75
Dec	-0.02	-0.01	0.05	0.45	1.35	2.4
Jan	0.03	0.19	0.37	0.77	1.7	3.1
Feb	0.16	0.31	0.25	0.55	1.35	2
Mar	0.1	0.185	0.2	0.25	-0.3	0.1
Apr	-0.05	-0.24	-0.2	-0.5	-0.5	-0.8
May	-0.28	-0.48	-0.5	-1.15	-1.2	-1.7
Jun	-0.19	-0.26	-0.8	-0.91	-1	-1.9
Jul	-0.12	-0.17	-0.495	-0.5	-0.95	-1.2
Aug	-0.06	-0.09	-0.24	-0.29	-1.1	-1.2
Sep	-0.02	-0.04	-0.1	-0.1	-0.3	-0.4

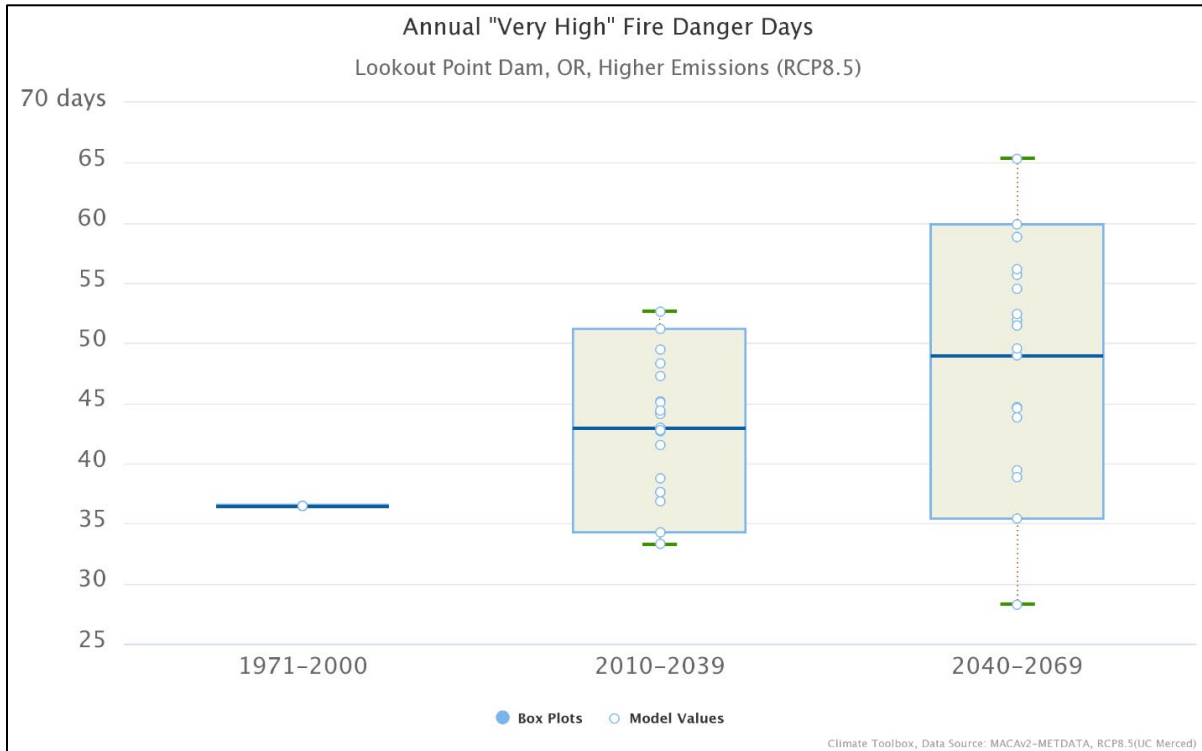
**Table 3-8. Fall Creek Dam Flow Change.**

FAL Median change - RCP 8.5 2030s and 2070s vs Historical baseline (1976-2005)						
Month	10th Percentile kcfs		Median kcfs		90th Percentile kcfs	
	2030s	2070s	2030s	2070s	2030s	2070s
Oct	-0.01	0.01	0	0.01	-0.24	-0.33
Nov	-0.04	0.05	0.02	0.07	0.5	0.4
Dec	-0.14	0.02	0.3	0.4	0.35	0.7
Jan	0.06	0.06	0.18	0.2	0.5	0.95
Feb	0.06	0.05	0.11	0.13	0.2	0.35
Mar	0.03	0.01	-0.13	-0.16	0	0.05
Apr	-0.06	-0.08	-0.25	-0.615	-0.3	-0.35
May	-0.04	-0.05	-0.15	-0.17	-0.25	-0.35
Jun	-0.01	0.02	0.05	0.05	-0.1	-0.15
Jul	-0.01	0.01	0.05	0.06	-0.05	-0.05
Aug	0.005	0	0.02	0.02	0	0
Sep	0	0	0.01	0.01	-0.05	-0.05

**Table 3-9. Lookout Point Dam Flow Change.**

LOP Median change - RCP 8.5 2030s and 2070s vs Historical baseline (1976-2005)						
Month	10th Percentile kcfs		Median kcfs		90th Percentile kcfs	
	2030s	2070s	2030s	2070s	2030s	2070s
Oct	-0.01	-0.02	-0.2	-0.3	-0.5	-1.5
Nov	-0.1	-0.12	-0.15	-0.2	2.6	1.8
Dec	-0.18	-0.08	0.05	0.9	3	5.5
Jan	0.2	0.5	1	2	4.5	9
Feb	0.74	1.09	1.3	2.1	4.35	4.9
Mar	0.45	0.65	0.7	1	1.5	2
Apr	-0.05	-0.55	-0.3	-1	-1.55	-1.8
May	-0.64	-1.29	-1	-2.6	-2	-3.05
Jun	-0.35	-0.55	-1.4	-2.2	-2	-4.5
Jul	-0.15	-0.2	-0.6	-0.8	-2.25	-3
Aug	-0.05	-0.11	-0.3	-0.4	-2	-2.05
Sep	0	-0.02	-0.2	-0.3	-1.05	-1.05

MF Willamette River projections present the same broad hydrologic trends as forecast for the rest of the Willamette Valley subbasins, with an increase in winter high flows (P90) indicated by the November thru March and relative increases in P90 median flows. Projected reduction of SWE will drive the transition to a fully rain-dominated basin. The historical spring pulse in April and May is projected to disappear in the future under both emission scenarios (RCP 4.5/8.5).



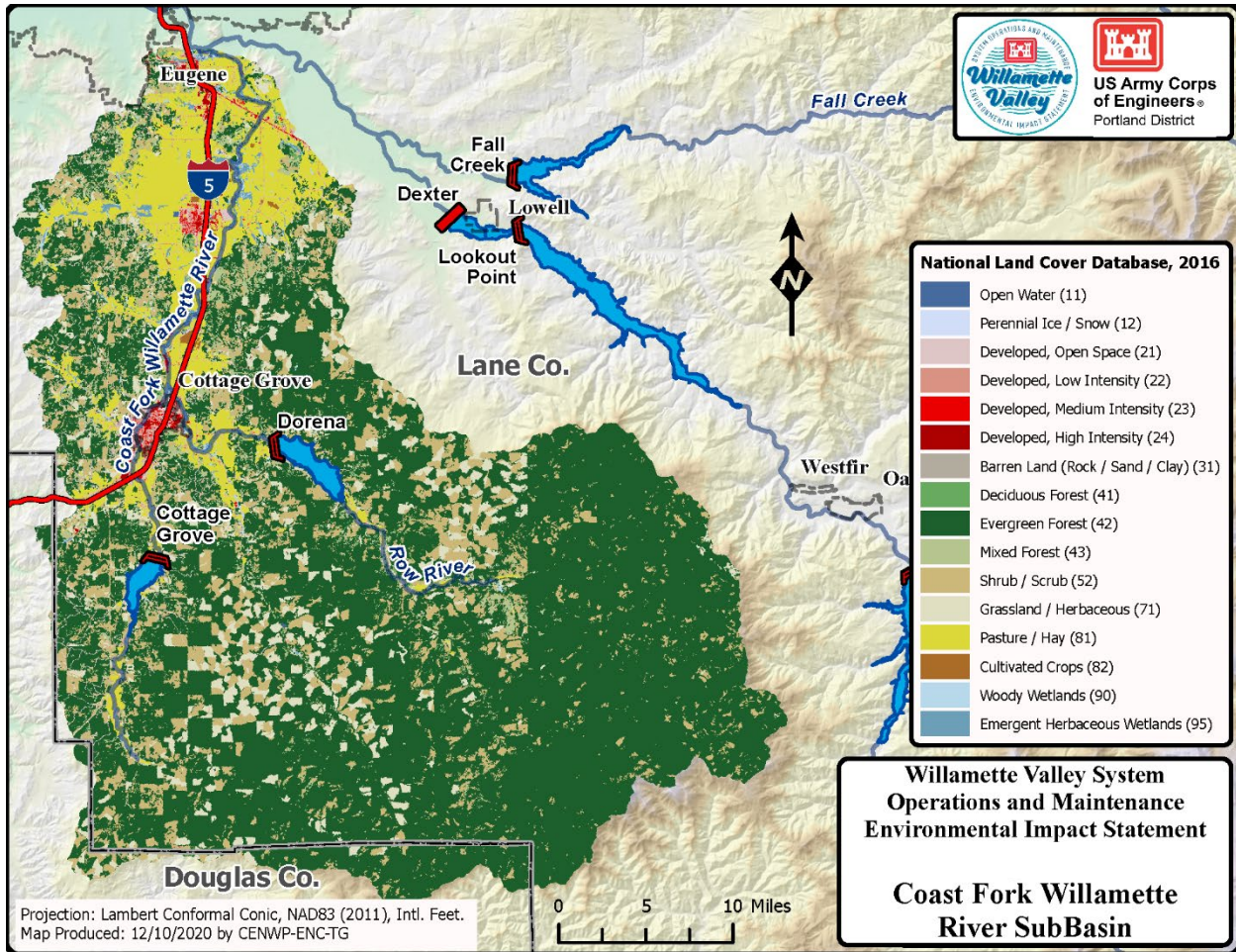
**Figure 3-57. Lookout Point Dam, Oregon Annual Very High Fire Danger Days.**

Lookout Point Dam is used as the proxy site for changing fire risk in the broader Middle Fork Willamette River Subbasin. It was chosen as the example site due to its central location in the subbasin. Conjecturally, Hills Creek Dam, being the headwater of the subbasin and composed of pristine and sensitive habitat, may be more vulnerable to future fires because of reduced accessibility, more rugged terrain, and denser vegetative cover and understory. Fall Creek Dam is similar in trending magnitude and variability relative to Lookout Point Dam.

### 3.2.10 Coast Fork Willamette River Subbasin

The Coast Fork (CF) Willamette River Subbasin is 667 square miles. The subbasin topography is steep, mountainous, and forested. However, the Coast Fork Willamette River Subbasin is at an average elevation of approximately 1,916 feet (NAVD88). The subbasin high point is about 5,950 feet (NAVD88) while the minimum elevation is 439 feet (NAVD88). The subbasin terminates at Creswell, OR.

*Willamette Valley System Operations and Maintenance  
Environmental Impact Statement*

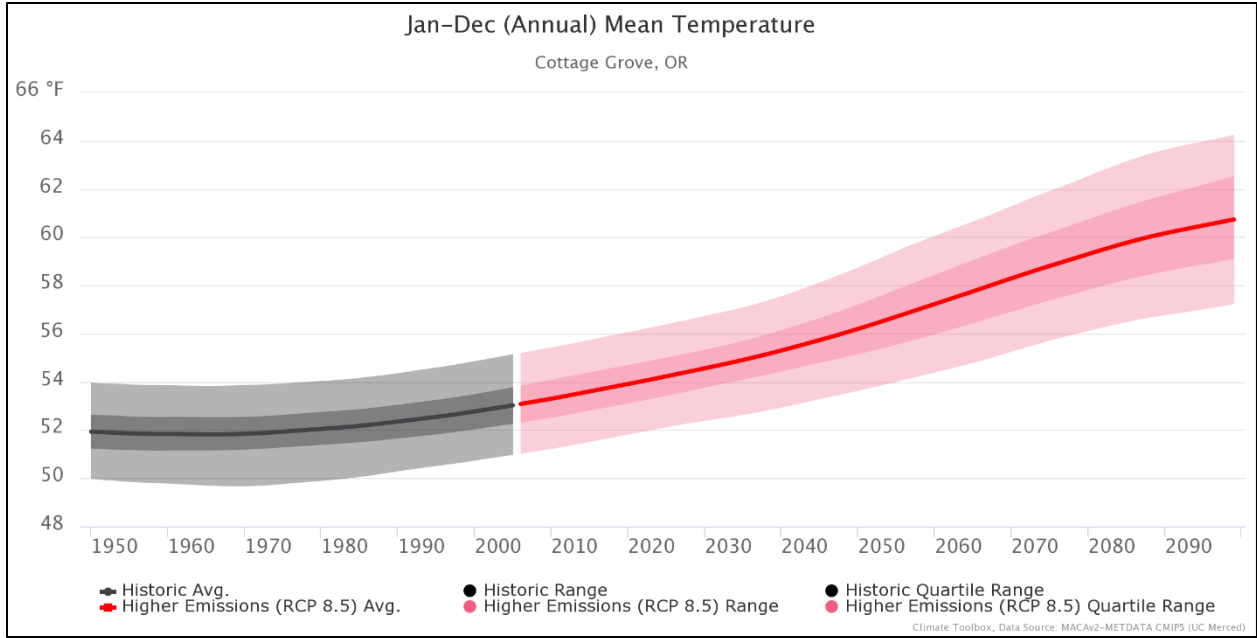


**Figure 3-58. Coast Fork Willamette River Subbasin.**

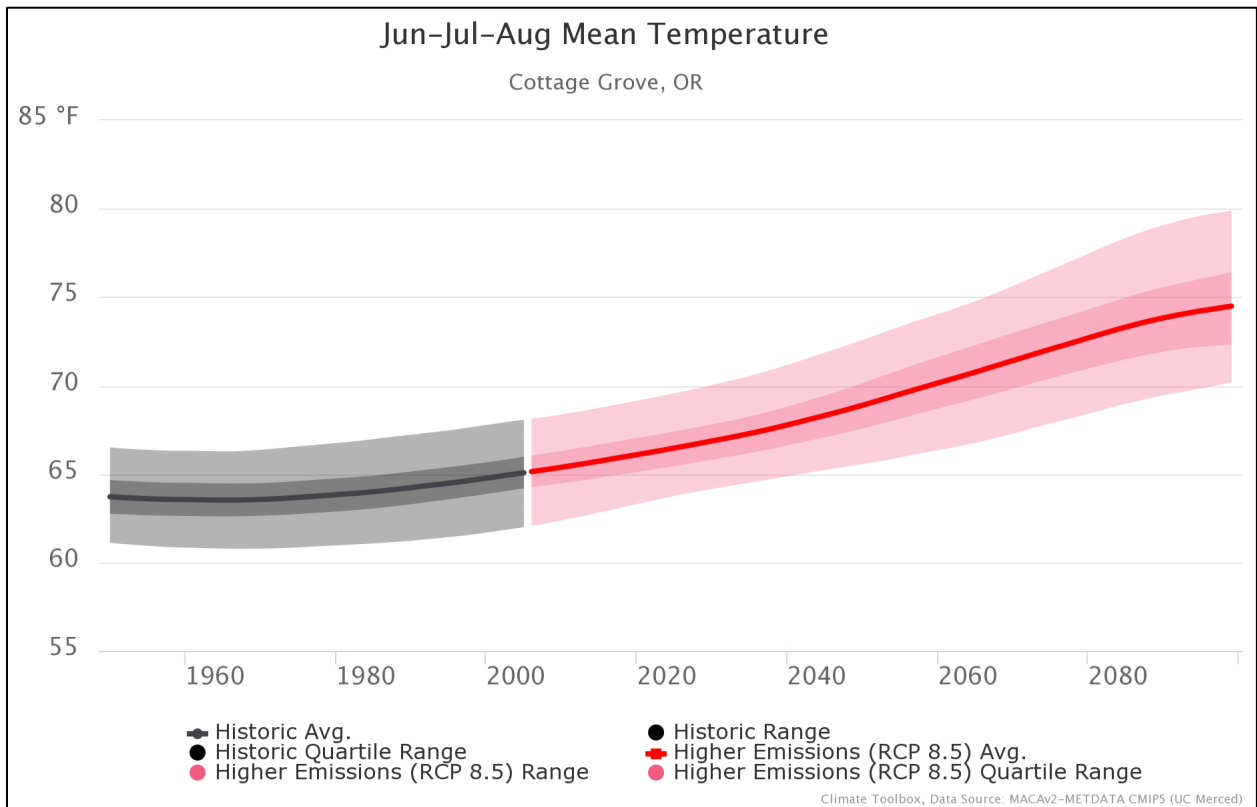
Cottage Grove Dam is a multipurpose (headwater) project on the Coast Fork (CF) Willamette River. Dorena Dam is a multipurpose project on the Row River, a tributary to the CF Willamette River. Dorena Dam is an earthfill structure with a concrete spillway and works in coordination with Cottage Grove Dam to provide flood risk management, water quality improvement, irrigation, recreation, and habitat for fish and wildlife (USACE 2020).

Projected hydroclimate changes in temperature and precipitation are comparable to trends expected across the Willamette Valley. Figure 3-59 and Figure 3-60 show that 1) annual warming is likely in the future and 2) the greatest degree of seasonal warming will be in the summer. Precipitation is projected to increase in the winter and decrease in the summer (Figure 3-61 and Figure 3-62). Normal precipitation in the summer months is already very low.

*Willamette Valley System Operations and Maintenance  
Environmental Impact Statement*

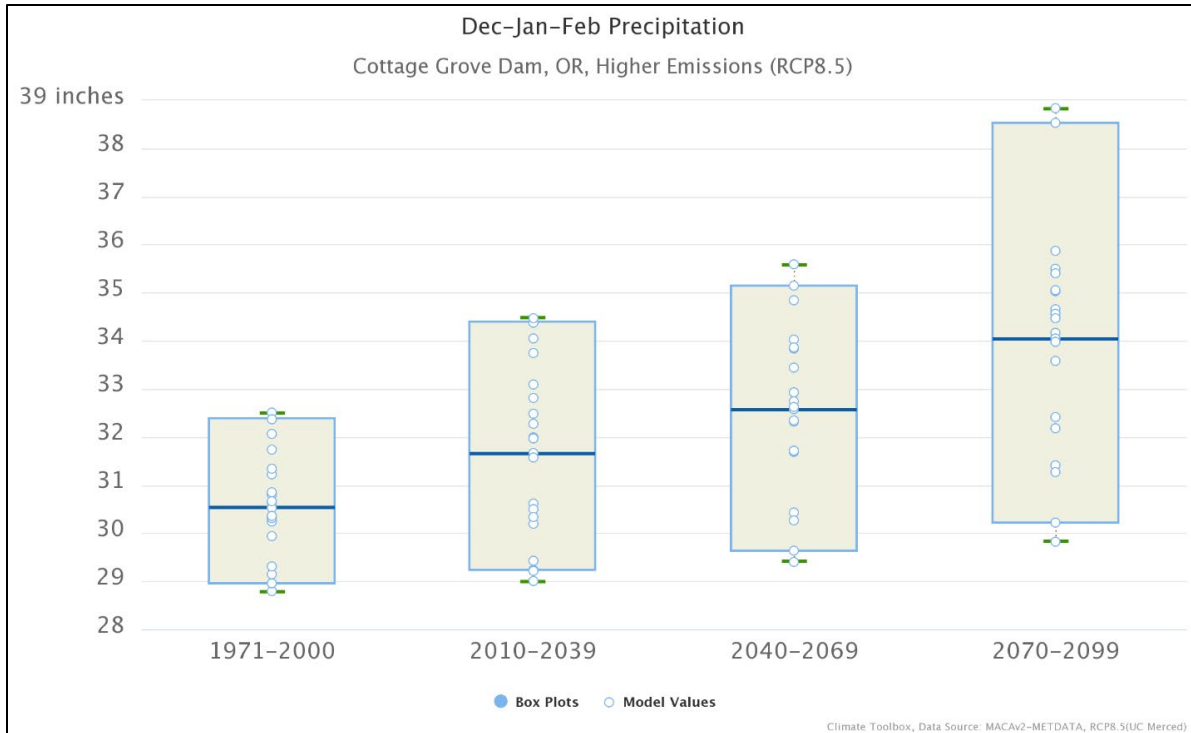


**Figure 3-59. Average Annual Temperature Trends at Cottage Grove Dam, Oregon, 1950–2100.**

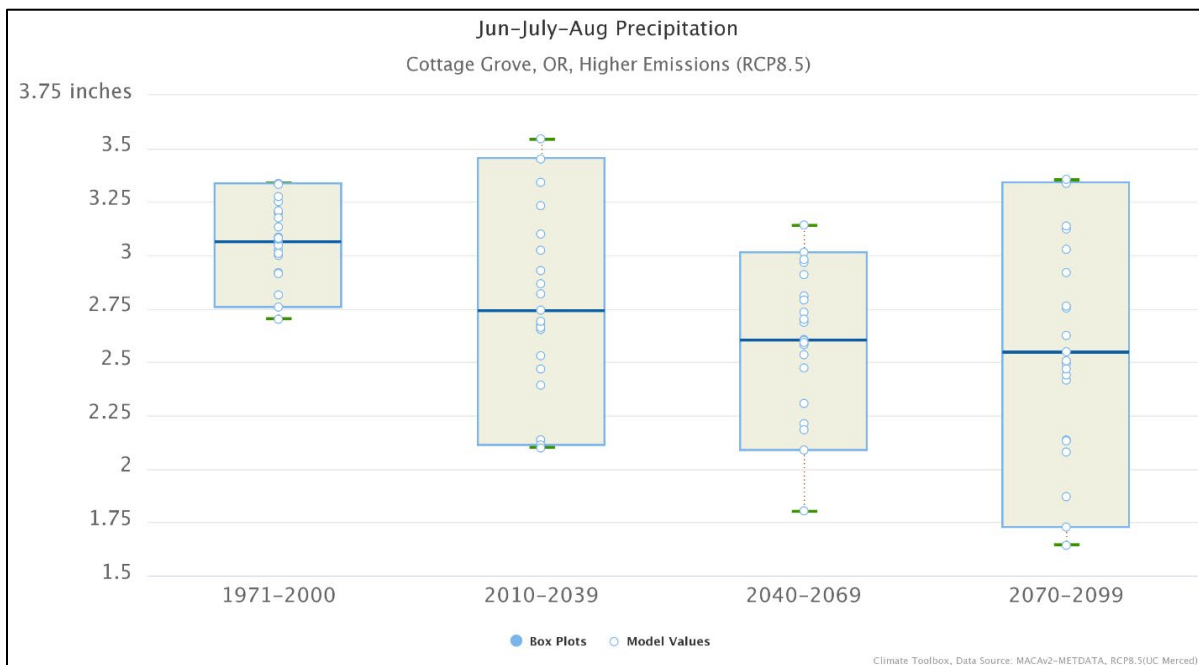


**Figure 3-60. Average Annual Summer Temperature Trends at Cottage Grove Dam, Oregon.**

*Willamette Valley System Operations and Maintenance  
Environmental Impact Statement*



**Figure 3-61. Median Winter Precipitation Trends at Cottage Grove Dam, Oregon.**



**Figure 3-62. Median Summer Precipitation Trends at Cottage Grove Dam, Oregon.**

The contributing area to the CF Willamette River at Cottage Grove Dam, OR is a lower elevation rain-dominated basin. Therefore, the projected changes are not as dramatic as shown for other subbasins discussed above. The primary change in future decades is toward greater winter

*Willamette Valley System Operations and Maintenance  
Environmental Impact Statement*

volume and flow duration with some increase of peak flows during high-water events. The peak month remains January.

During the summer, median streamflow volume is projected to decrease. Likely increased ambient temperatures could translate to increased need for water temperature regulation. Higher temperatures will most likely stress resident (and listed) fish species. Lower base flow during the summer and fall months will likely complicate maintaining the conservation pool as demand rises and additional variability in the late winter and early spring could complicate refill. Mean Row River streamflows at Dorena Dam are projected to be higher than historical averages in winter months (starting October through March). Higher runoff would be due to increased duration and intensity of winter rainfall events and higher winter baseflow in the hills that feed into the subbasin. Winter outflows and storage fluctuations could become more variable as reservoirs store and evacuate water for downstream flood risk management.

Willamette Valley System Operations and Maintenance  
Environmental Impact Statement

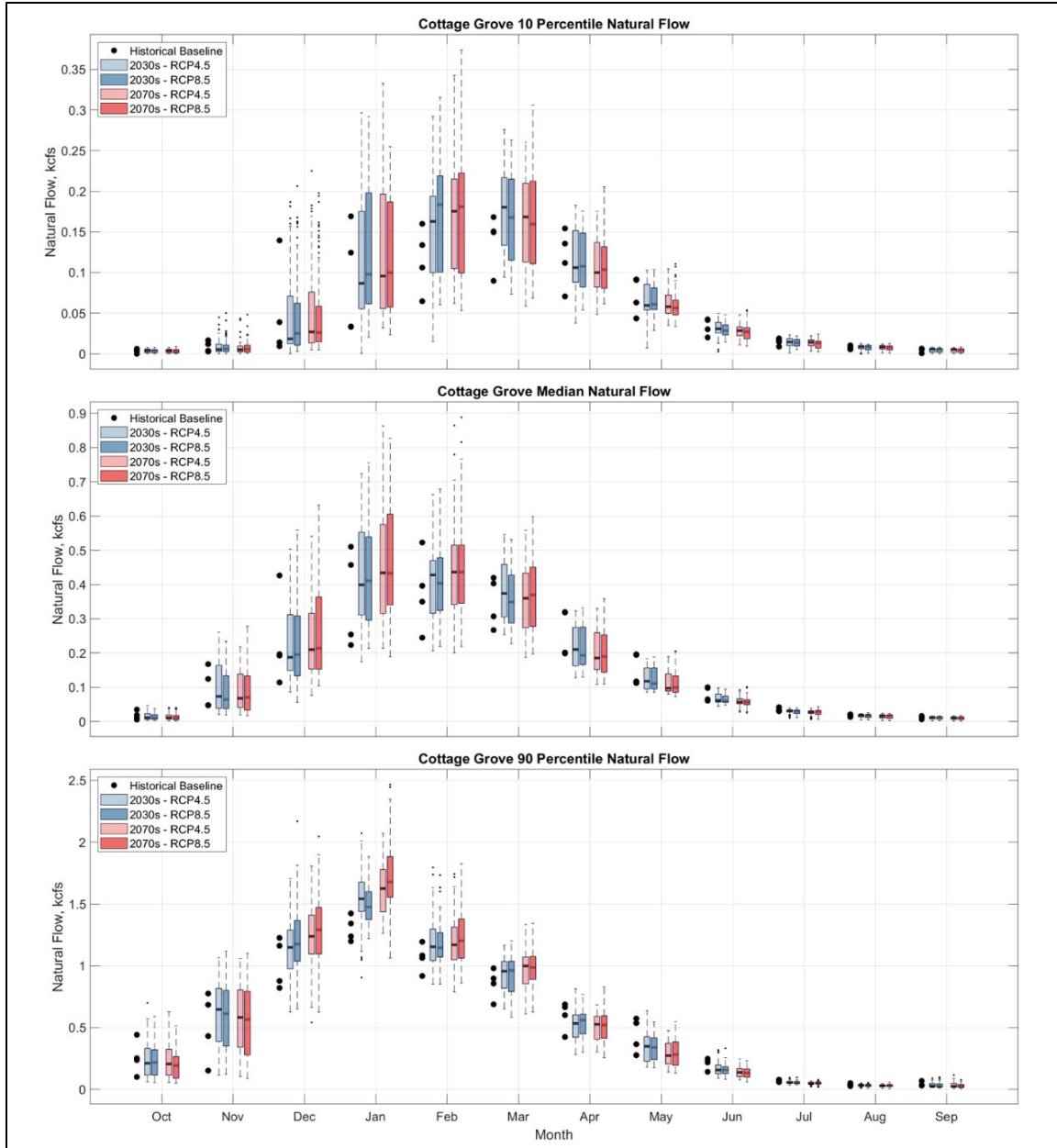
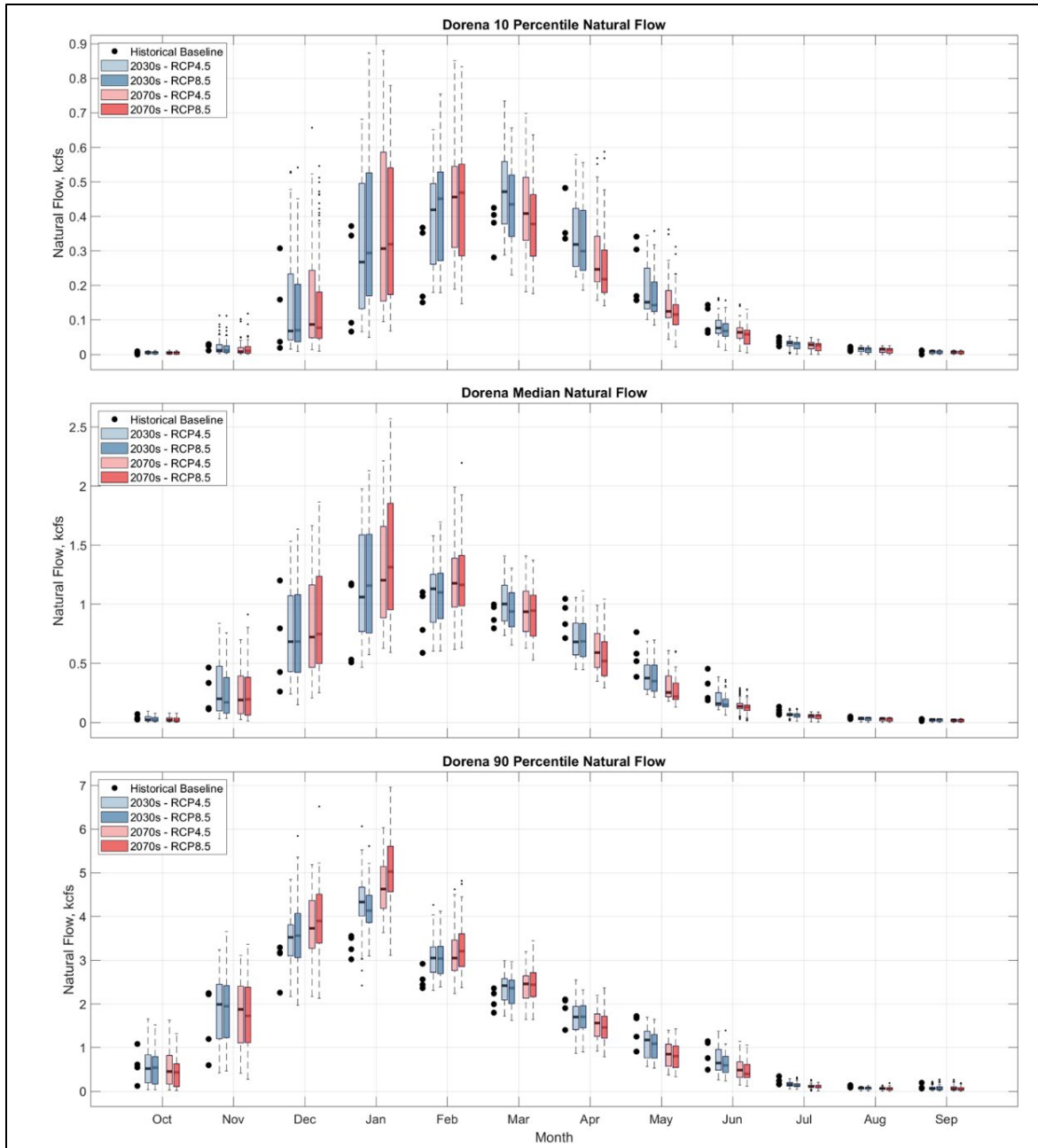


Figure 3-63. Coast Fork Willamette River at Cottage Grove Dam, Oregon Summary Hydrographs.

*Willamette Valley System Operations and Maintenance  
Environmental Impact Statement*



**Figure 3-64. Row River at Dorena Dam, Oregon Summary Hydrographs.**

The tables below correspond to the above summary hydrograph figures. The future pattern of increased runoff beginning in November through March (slight relative increase) will change to substantial decreases in the summer months. The overall annual changes are slightly upward in this and other subbasins of the WVS.

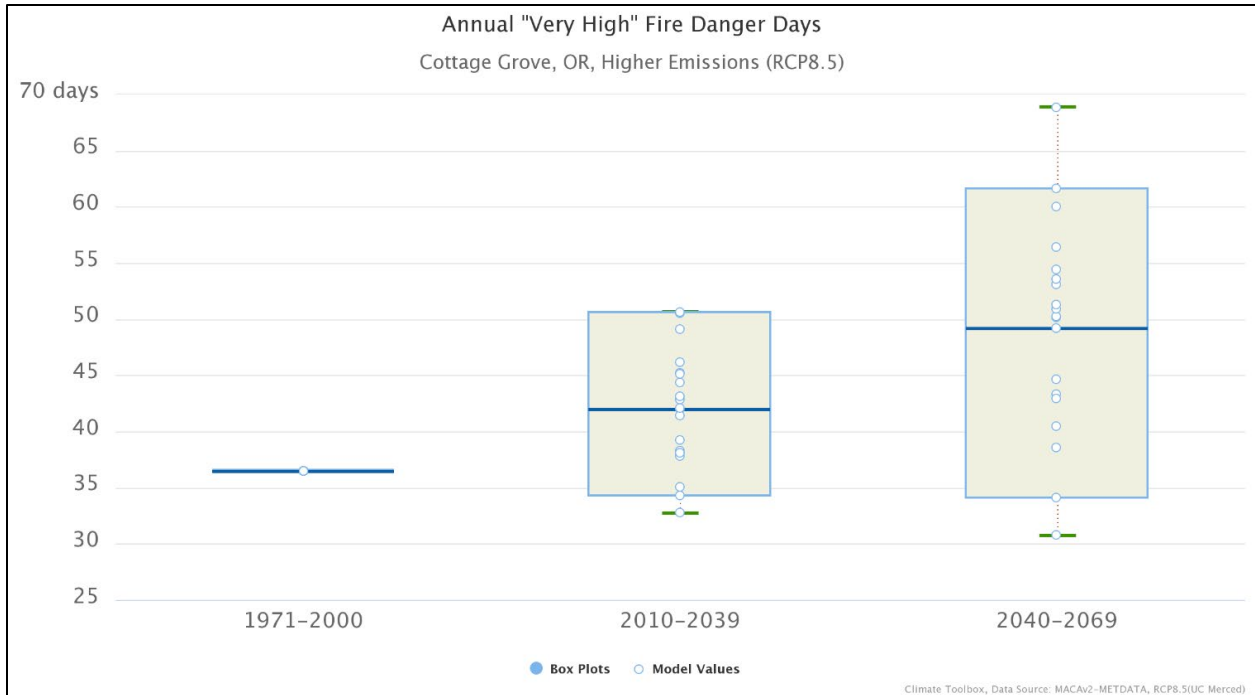
Willamette Valley System Operations and Maintenance  
Environmental Impact Statement

**Table 3-10. Cottage Grove Dam Flow Change.**

COT Median change - RCP 8.5 2030s and 2070s vs Historical baseline (1976-2005)						
Month	10th Percentile kcfs		Median kcfs		90th Percentile kcfs	
	2030s	2070s	2030s	2070s	2030s	2070s
Oct	0	0	0	0	-0.05	-0.07
Nov	-0.001	-0.001	-0.06	-0.06	0.14	0.09
Dec	-0.025	-0.025	-0.055	-0.035	0.2	0.3
Jan	0.033	0.033	0.025	0.035	0.24	0.4
Feb	0.07	0.065	0.04	0.07	0.05	0.1
Mar	0.025	0.02	0	0.01	0.1	0.15
Apr	-0.015	-0.016	-0.055	-0.055	0	-0.01
May	-0.015	-0.02	-0.045	-0.05	-0.1	-0.15
Jun	0	-0.002	-0.01	-0.02	-0.05	-0.1
Jul	0	0	-0.005	-0.005	-0.01	-0.01
Aug	0	0	0	0	-0.01	-0.01
Sep	0	0	0	0	-0.01	-0.01

**Table 3-11. Dorena Dam Flow Change.**

DOR Median change - RCP 8.5 2030s and 2070s vs Historical baseline (1976-2005)						
Month	10th Percentile kcfs		Median kcfs		90th Percentile kcfs	
	2030s	2070s	2030s	2070s	2030s	2070s
Oct	0	0	-0.03	-0.03	0	-0.2
Nov	-0.005	-0.005	-0.05	-0.04	0.65	0.55
Dec	0.015	0.015	-0.09	0.06	0.97	1.32
Jan	0.035	0.05	0.4	0.55	0.9	1.8
Feb	0.17	0.2	0.28	0.4	0.2	0.3
Mar	0.05	0.02	0.05	0.05	0.05	0.1
Apr	-0.12	-0.21	-0.15	-0.29	0	-0.3
May	-0.11	-0.14	-0.15	-0.31	-0.2	-0.4
Jun	-0.04	-0.04	-0.15	-0.15	-0.2	-0.5
Jul	-0.01	-0.01	-0.05	-0.05	-0.1	-0.1
Aug	0	0	-0.01	-0.01	-0.05	-0.05
Sep	0	0	-0.01	-0.01	-0.05	-0.05



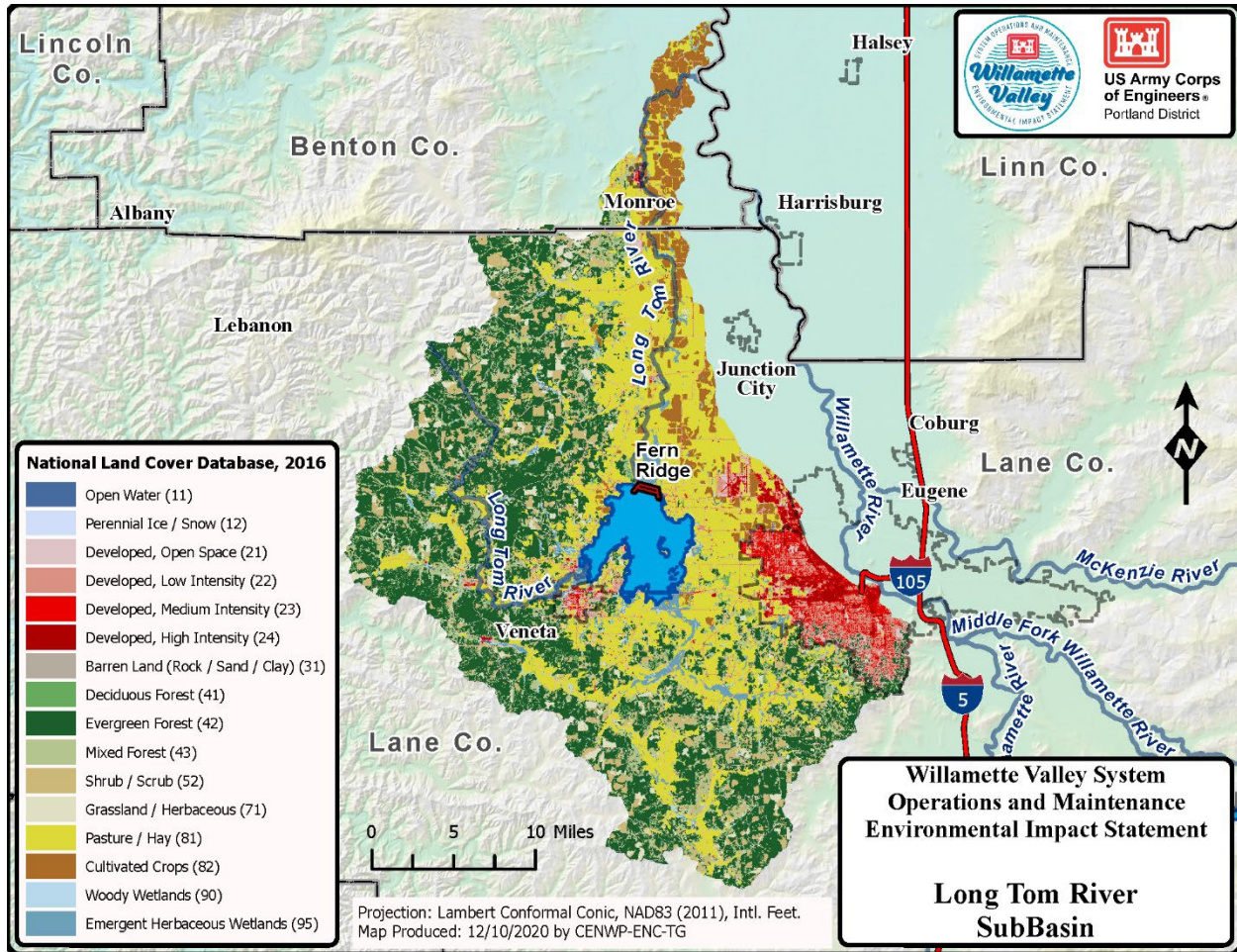
**Figure 3-65. Dorena Dam, Oregon Annual Very High Fire Danger Days.**

Fire risk at Dorena Dam is representative for the Coast Fork Willamette River Subbasin. The overall trends are the same as for the rest of the subbasins in the Willamette Valley.

### 3.2.11 Long Tom River Subbasin

The Long Tom River Subbasin is the smallest described subbasin at 392 square miles. The subbasin's topography is milder compared to the others as well. Average elevation is approximately 636 feet (NAVD88), the high point is about 2,095 feet (NAVD88), and the minimum elevation is 275 feet (NAVD88). The subbasin terminates at approximately Monroe, OR. The primary USACE project is Fern Ridge Dam.

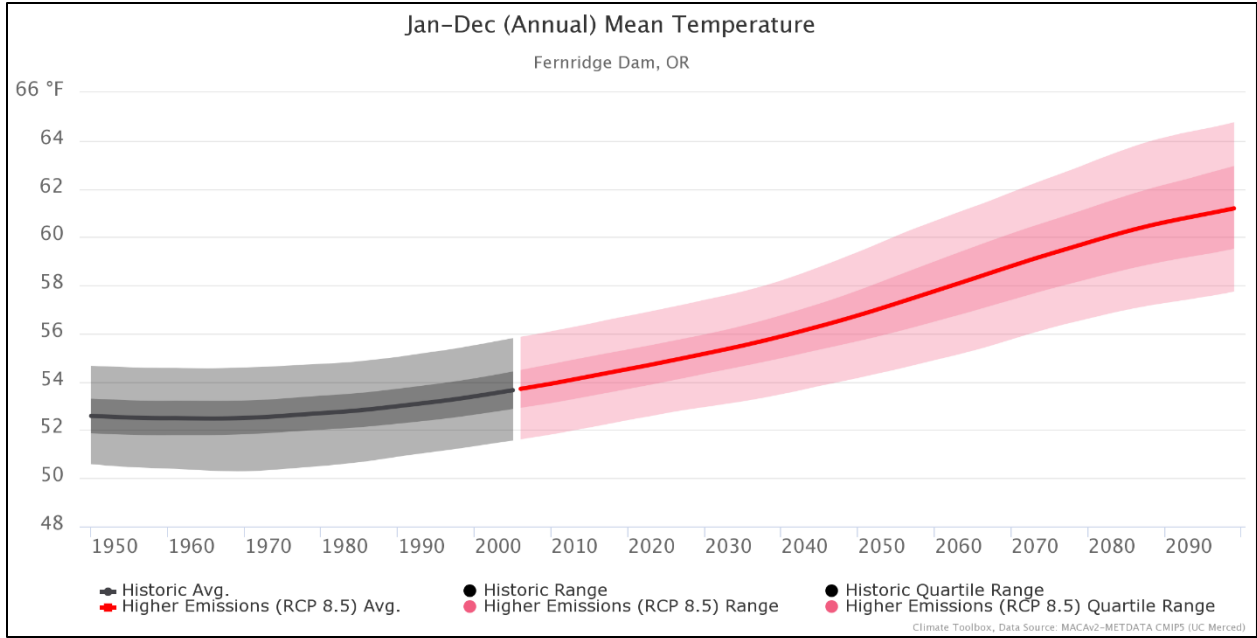
*Willamette Valley System Operations and Maintenance  
Environmental Impact Statement*



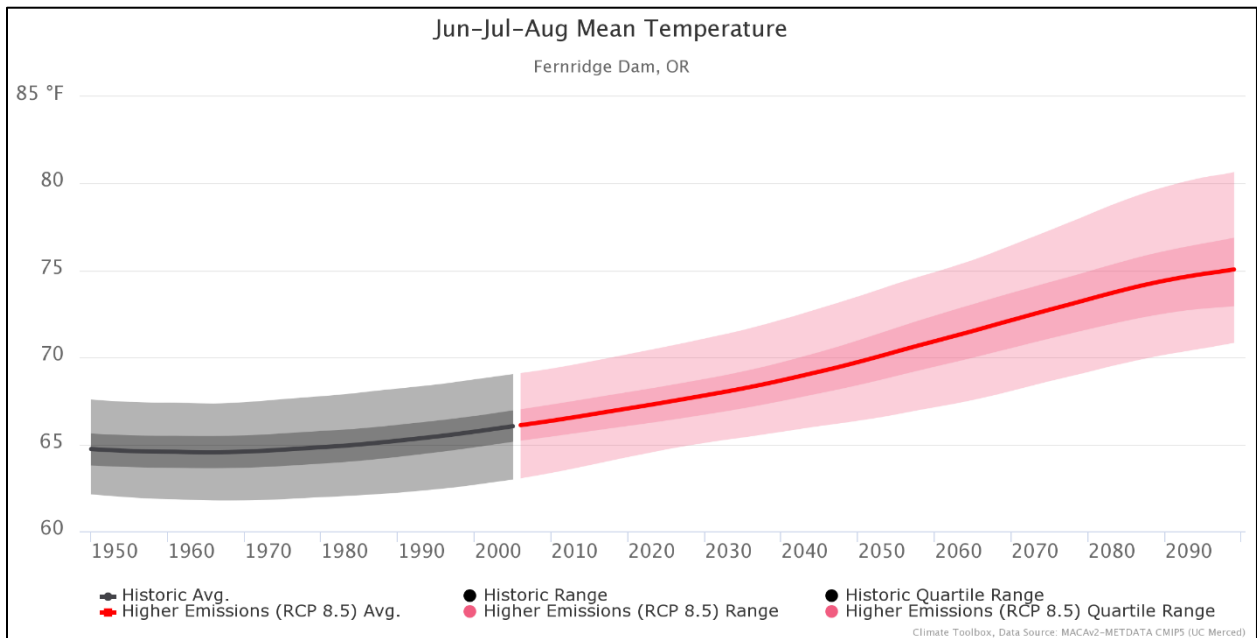
**Figure 3-66. Long Tom River Subbasin.**

The reservoir surface area is large (9,400 acres), and it is a popular site for recreation (sailing, power boating, etc.). The project is authorized for multiple purposes, including flood risk management, recreation, irrigation, municipal and industrial water supply, and water quality. This subbasin, like the Coast Fork Willamette River Subbasin, has very small populations of salmonids; therefore, there is not a dedicated fish operation at this project. Downstream reaches are surrounded by extensive farm fields. The project is a primary source of irrigation flows to these areas.

*Willamette Valley System Operations and Maintenance  
Environmental Impact Statement*

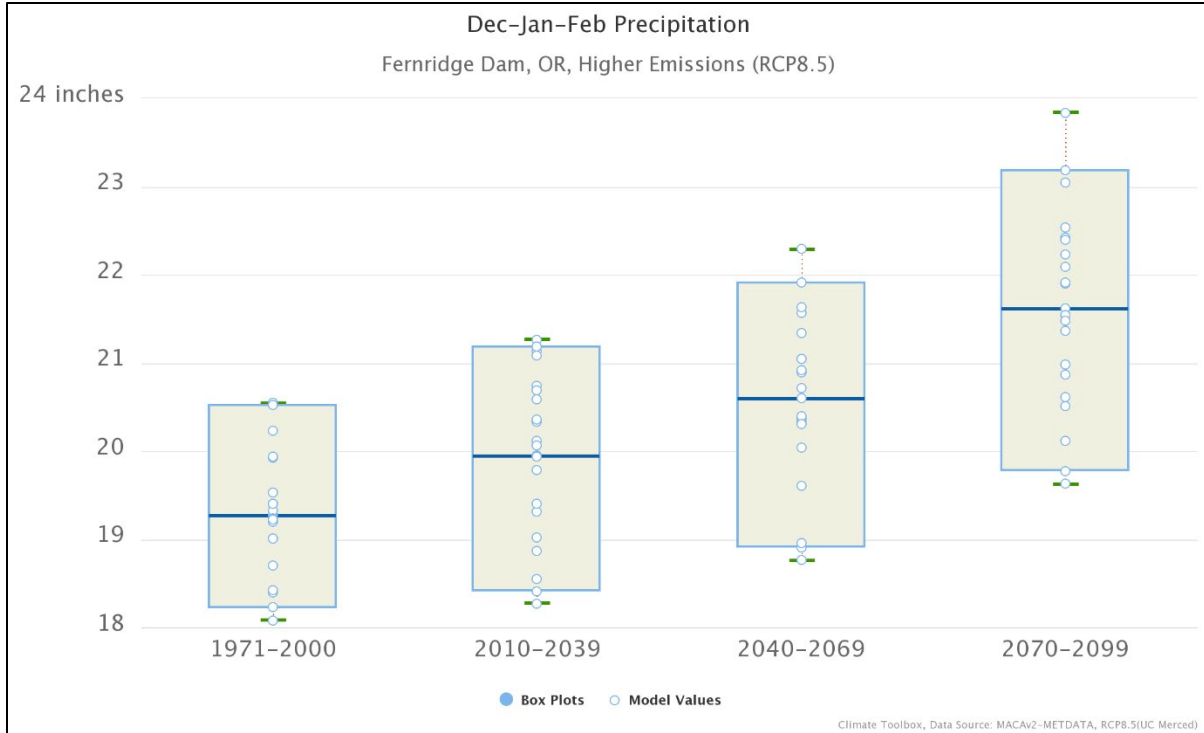


**Figure 3-67. Average Annual Temperature Trends at Fern Ridge Dam, Oregon.**

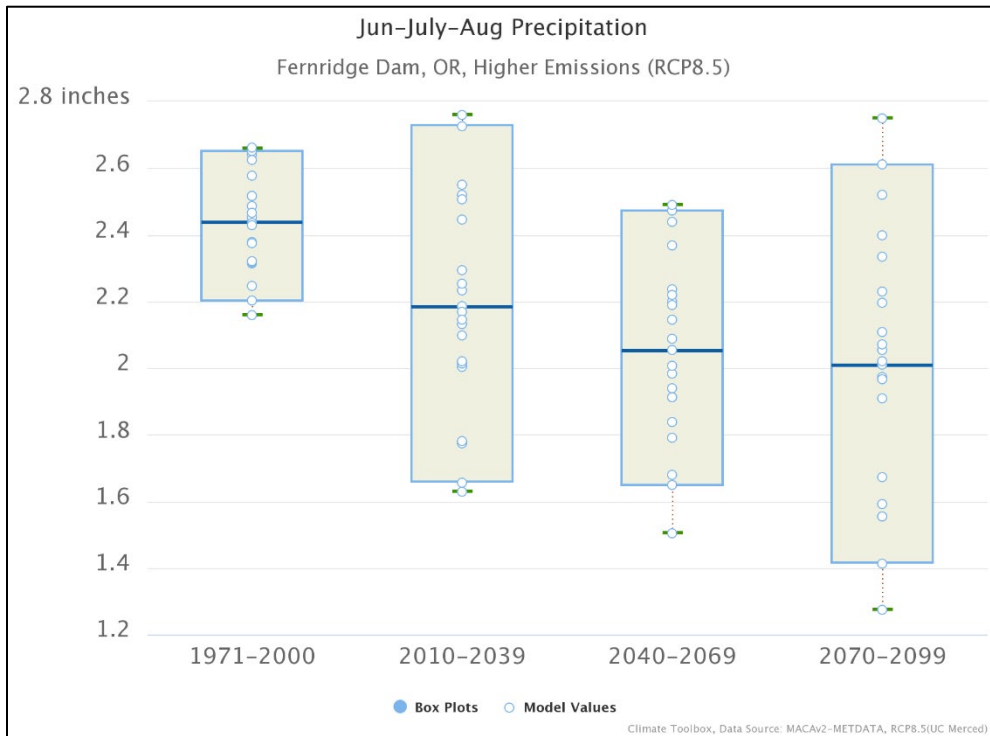


**Figure 3-68. Average Annual Summer Temperature Trends at Fern Ridge Dam, Oregon.**

*Willamette Valley System Operations and Maintenance  
Environmental Impact Statement*



**Figure 3-69. Median Winter Precipitation Trends at Fern Ridge Dam, Oregon.**



**Figure 3-70. Median Summer Precipitation Trends at Fern Ridge Dam, Oregon.**

Willamette Valley System Operations and Maintenance  
Environmental Impact Statement

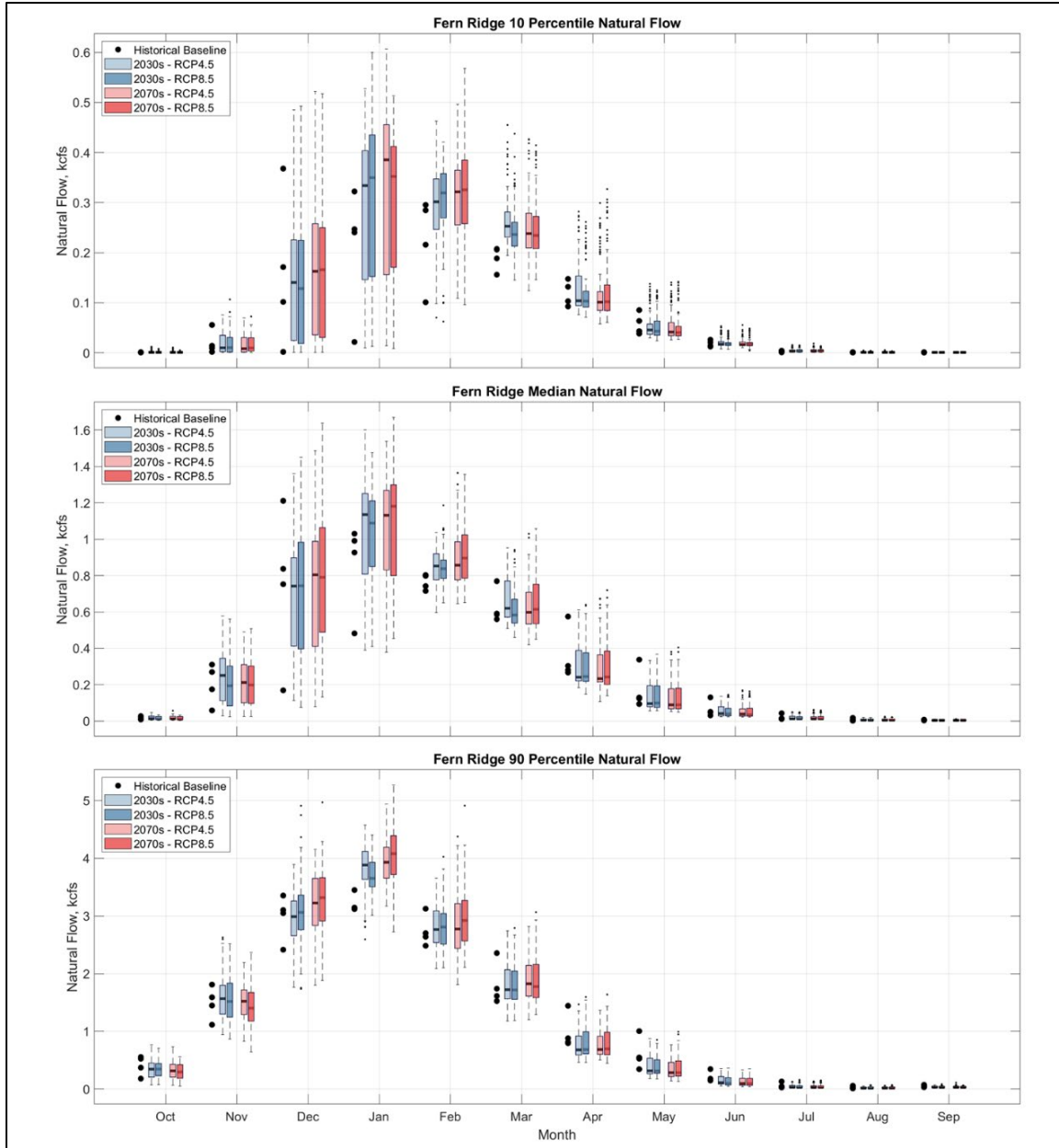
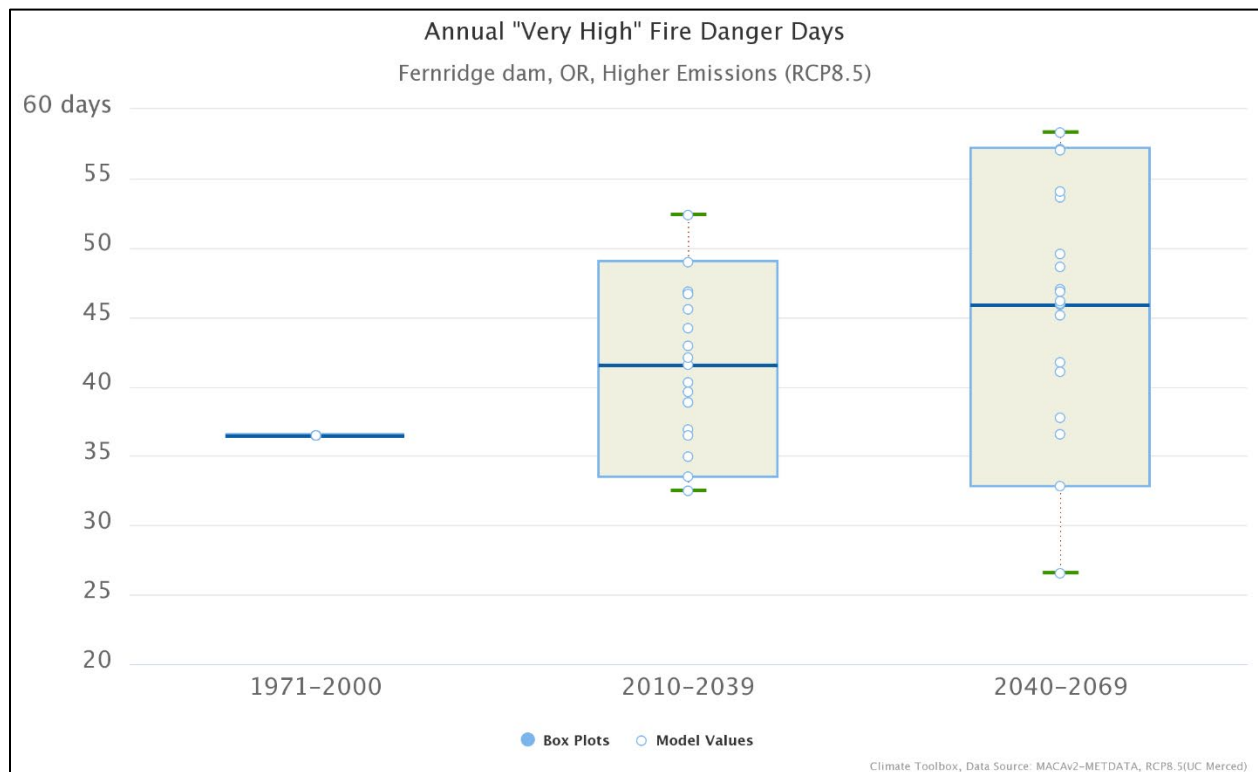


Figure 3-71. Long Tom River at Fern Ridge Dam, Oregon Summary Hydrographs.

**Table 3-12. Fern Ridge Dam Median Flow Change.**

FRN Median change - RCP 8.5 2030s and 2070s vs Historical baseline (1976-2005)						
Month	10th Percentile kcfs		Median kcfs		90th Percentile kcfs	
	2030s	2070s	2030s	2070s	2030s	2070s
Oct	0	0	0	0	-0.1	-0.15
Nov	-0.005	-0.005	-0.01	-0.01	0	-0.1
Dec	-0.03	0.02	0.04	0.05	0.2	0.4
Jan	0.17	0.17	0.28	0.37	0.3	0.8
Feb	0.11	0.14	0.02	0.11	-0.1	0
Mar	0.05	0.05	-0.11	-0.09	-0.1	0
Apr	-0.02	-0.02	-0.16	-0.16	0.7	0.7
May	-0.01	-0.01	-0.06	-0.06	-0.3	-0.35
Jun	0	0	-0.07	-0.07	-0.2	-0.2
Jul	0	0	-0.005	-0.005	-0.18	-0.18
Aug	0	0	0	0	-0.09	-0.09
Sep	0	0	0	0	-0.09	-0.09

As shown in Figure 3-71 and corresponding Table 3-12, Long Tom River streamflows are likely to be more variable, with ensemble projections showing some negative (albeit, minimal) median shifts in March. Still, the future WVS pattern of wetter winters and lower baseflows in the summer still holds.



**Figure 3-72. Fern Ridge Dam, Oregon Annual Very High Fire Danger Days.**

Source: climatetoolbox.org, 2021.

Fire risk in the Long Tom River Subbasin at Fern Ridge Dam, OR is reflective of the similar fire risk in the Upper Willamette River Subbasin at Salem and Albany, OR for example. These valley

*Willamette Valley System Operations and Maintenance  
Environmental Impact Statement*

floor locations show median changes that are relatively lower as compared to higher elevation, wilder subbasins (North and South Santiam River Subbasins, for example). The overall trend is toward higher fire risk in the future.

#### 4. REFERENCES

- Abatzoglou, J., D. Rupp, L. O'Neill, and M. Sadegh. 2021. Compound extremes drive the Western Oregon Wildfires of September 2020. *Geophysical Research Letters*. Volume 48(8). Report #: ARTN e2021GL092520. Retrieved from <https://escholarship.org/uc/item/8k03m5mp>. <http://dx.doi.org/10.1029/2021GL092520>
- Alden Research Laboratory, Inc. 2021. Alden Research Laboratory, Inc., McKenzie and Santiam Post-wildfire Hydrology and Hydraulics, Draft Literature Review, W9127N-18-D-0002, Task Order No. W9127N21F0199. December 2021.
- Bradley, B. A., M. Oppenheimer, and D. S. Wilcove. 2009. Climate change and plant invasions: restoration opportunities ahead? *Global Change Biology*. Volume 15, pages 1511–1521.
- Brummer, T. J., K. T. Taylor, J. Rotella, B. D. Maxwell, L. J. Rew, and M. Lavin. 2016. Drivers of *Bromus tectorum* abundance in the western North American sagebrush steppe. *Ecosystems*. Volume 19, pages 986–1000.
- Chapman, D. S., T. Haynes, S. Beal, F. Essl, and J. M. Bullock. 2014. Phenology predicts the native and invasive range limits of common ragweed. *Global Change Biology*. Volume 20, pages 192–202.
- Climate Impacts Research Consortium (CIRC). 2019. Mooney, A., N. Gilles, K. Hegewisch, J. Abatzoglou, and M. Dalton, presenters. “The Northwest Climate Toolbox Workbook: Discovering and applying your climate data story for climate adaptation planning,” Corvallis, Oregon: The Pacific Northwest Climate Impacts Research Consortium (CIRC), College of Earth, Ocean, and Atmospheric Sciences, Oregon State University.
- CIRC. 2020. The Climate Toolbox. By the Pacific Northwest Climate Impacts Research Consortium (CIRC), College of Earth, Ocean, and Atmospheric Sciences, Oregon State University, 2019. Website: <https://climatetoolbox.org/>. Last accessed: September 2020.
- Gervais, J.A., R. Kovach, A. Sepulveda, R. K. Al-Chokhachy, J. J. Giersch, and C. C. Muhlfeld. 2020. Climate-induced expansions of invasive species in the Pacific Northwest, North America: a synthesis of observations and projections. *Biological Invasions*. Volume 22, pages 2163–2183. <https://doi.org/10.1007/s10530-020-02244-2>
- Hegewisch, K.C., V. Laquindanum, E. Fleishman, H. Hartmann, M. and Mills-Novoa 2022. Climate Toolbox Tool Summary series. Accessed: 2022
- Intergovernmental Panel on Climate Change (IPCC). 2022a. Intergovernmental Panel on Climate Change. <https://www.ipcc.ch/>. Last accessed: 2022.

*Willamette Valley System Operations and Maintenance  
Environmental Impact Statement*

- IPCC. 2022b. Intergovernmental Panel on Climate Change.  
<https://www.ipcc.ch/report/ar5/wg1/aism-annex-i-atlas-of-global-and-regional-climate-projections-supplementary-material-rcp8-5/>. Last accessed: 2022.
- McDonald, A., S. Riha, A. DiTommaso, and A. DeGaetano. 2009. Climate change and the geography of weed damage: analysis of US maize systems suggests the potential for significant range transformations. *Agriculture, Ecosystems and Environment*. Volume 130, pages 131–140. <https://doi.org/10.1016/j.agee.2008.12.007>
- National Oceanic and Atmospheric Administration (NOAA). 2021. May 4, 2021, National Oceanic and Atmospheric Administration, NOAA Delivers New U.S. Climate Normals. <https://www.ncei.noaa.gov/news/noaa-delivers-new-us-climate-normals>.
- Oregon Climate Change Research Institute (OCCRI). 2015. Revised March 2016. Prepared for U.S. Army Corps of Engineers by Oregon Climate Change Research Institute. Historical Trends and Future Projections of Climate and Streamflow in the Willamette Valley and Rogue River Basins.
- OCCRI. 2023. Sixth Oregon Climate Assessment. E. Fleishman, editor. Oregon Climate Change Research Institute, Oregon State University, Corvallis, Oregon.  
<https://blogs.oregonstate.edu/occri/oregon-climate-assessments>.
- River Management Joint Operating Committee (RMJOC). 2018. Climate and Hydrology Datasets for RMJOC Long-Term Planning Studies: Second Edition (RMJOC-II), Part I: Hydroclimate Projections and Analyses.  
<https://usace.contentdm.oclc.org/utis/getfile/collection/p266001coll1/id/10562>
- RMJOC. 2020. Climate and Hydrology Datasets for RMJOC Long-Term Planning Studies: Second Edition (RMJOC-II), Part II: Columbia River Reservoir Regulation and Operations—Modeling and Analyses.  
<https://usace.contentdm.oclc.org/digital/collection/p266001coll1/id/9936/rec/1>.
- U.S. Army Corps of Engineers (USACE). 1997. U.S. Army Corps of Engineers. Portland District. Hydrologic, Coastal, and River Engineering Center. February 1996 Postflood Report: Hydrometeorological Evaluation, USACE, Portland, OR.
- USACE. 2012. U.S. Army Corps of Engineers. Portland District. November 2012. Willamette River Basin Operational Measures Evaluation Report.
- USACE. 2013. U.S. Army Corps of Engineers. July 2013. Sustainable Rivers Project, Evaluation of E-Flow Implementation and Effects in the Willamette Basin using ResSim Modeling.
- USACE. 2016. U.S. Army Corps of Engineers. Portland District. July 2016. Willamette Basin Extreme Storms Report.

*Willamette Valley System Operations and Maintenance  
Environmental Impact Statement*

- USACE. 2019. U.S. Army Corps of Engineers. December 2019. Willamette Basin Review Feasibility, Integrated Feasibility Report and Environmental Assessment.
- USACE. 2020. U.S. Army Corps of Engineers. Climate Preparedness and Resilience CoP Applications Portal. <https://maps.crrel.usace.army.mil/projects/rcc/portal>. Last accessed September 2020.
- USACE. 2020. U.S. Army Corps of Engineers. <https://www.nwp.usace.army.mil/Locations/Willamette-Valley/>. Last accessed September 2020.
- USACE. 2019. U.S. Army Corps of Engineers. December 2019. Willamette Basin Year in Review January 1 – December 31, 2019.
- U.S. Army Corps of Engineers (USACE), Bureau of Reclamation, and Bonneville Power Administration. 2020. Columbia River System Operations (CRSO) Environmental Impact Statement. <https://www.nwd.usace.army.mil/CRSO/Final-EIS/>.
- U.S. Global Change Research Program (USGCRP). 2017. Climate Science Special Report: Fourth National Climate Assessment, Volume I. D. J. Wuebbles, D. W. Fahey, K. A. Hibbard, D. J. Dokken, B. C. Stewart, and T. K. Maycock, eds. U.S. Global Change Research Program, Washington, D.C. Accessed at doi:10.7930/J0J964J6.
- USGCRP. 2018. Impacts, Risks, and Adaptation in the United States: Fourth National Climate Assessment, Volume II: [Reidmiller, D. R., C. W. Avery, D. R. Easterling, K. E. Kunkel, K. L. M. Lewis, T. K. Maycock, and B. C. Stewart (eds.)]. U.S. Global Change Research Program, Washington, DC, USA, 1515 pages. doi: 10.7930/NCA4.2018.